



WaterCar EV

OWNER'S MANUAL

LSV Road Operation · Marine Module Operation · Amphibious Transition Operation
— 2025–2026

Version 23.0

WaterCar Inc. | 17403 Newhope St., Fountain Valley, CA 92708
info@watercar.com | www.watercar.com | (714) 253-7186

Important Notice to Owners

This manual covers the WaterCar EV as configured at the time of delivery. WaterCar Inc. reserves the right to make improvements, modifications, or specification changes at any time without prior notice and without obligation to update previously delivered vehicles.

This vehicle is manufactured in conformance with applicable federal Low Speed Vehicle requirements under 49 CFR Part 571.500 (FMVSS 500). A 17-character Vehicle Identification Number (VIN) is assigned at manufacture pursuant to 49 CFR Part 565. Road operation requirements vary by jurisdiction. The owner is responsible for verifying compliance with all applicable state and local laws prior to operation.

Any modifications made after delivery are the sole responsibility of the vehicle owner and may affect road legality, warranty coverage, and safe operation.

WaterCar Inc. | info@watercar.com | www.watercar.com | (714) 253-7186

Vehicle & Vessel Registration Information

Complete this page at delivery and retain for your records.

Field	Value
OWNER NAME	
ADDRESS	
PHONE	
EMAIL	
DATE OF DELIVERY	
DEALER NAME	
DEALER PHONE	
VIN (VEHICLE SERIAL NO.)	
HIN (HULL ID — Marine Package)	
OUTBOARD ENGINE SERIAL NO.	
ECO BATTERY SERIAL NO.	
EPOCH BATTERY SERIAL NO.	
TRAILER VIN	
STATE REGISTRATION NO.	
USCG DOCUMENTATION NO.	

Delivery Acknowledgment Form

Complete at time of vehicle delivery and retain for your records.

Field	Value
OWNER NAME	
DATE OF DELIVERY	
VIN (VEHICLE SERIAL NO.)	
HIN (HULL ID — Marine Package)	
OUTBOARD ENGINE SERIAL NO.	
ECO BATTERY SERIAL NO.	
EPOCH BATTERY SERIAL NO.	
DELIVERY LOCATION	
DELIVERED BY (WaterCar Rep)	

Owner Acknowledgment:

- I have received and reviewed this Owner's Manual in its entirety.
- I have received a complete vehicle orientation and demonstration from an authorized WaterCar representative.
- I understand this vehicle is classified as a Low Speed Vehicle (LSV) limited to 25 MPH on public roads.
- I understand that any modifications made after delivery are my sole responsibility and may affect road legality, warranty coverage, and safe operation.
- I have received all applicable OEM manuals (Mercury Marine, Eco Battery, Epoch® Battery).
- I confirm the vehicle was delivered in factory configuration in conformance with applicable federal LSV requirements.

If this vehicle includes the Marine Package: I understand it is also a federally registered recreational vessel identified by a Hull Identification Number (HIN) and subject to U.S. Coast Guard regulations. I am responsible for complying with all applicable federal, state, and local boating laws, vessel registration requirements, and operator licensing. I have been briefed on the dual-environment nature of this vehicle and the operational differences between road and water modes.

OWNER SIGNATURE: _____ DATE: _____	WATERCAR REPRESENTATIVE: _____ DATE: _____
--	--

SECTION 1

Introduction & Welcome

1. Introduction & Welcome

1.1 Welcome to the WaterCar Family

[IMAGE PLACEHOLDER]

Welcome letter — WaterCar letterhead with personal message from Dave March and Michael J. March, Co-Founders

Welcome to the family of WaterCar owners and congratulations on your purchase of your new WaterCar EV. The WaterCar EV represents over two decades of innovation — beginning with Dave March's restoration of a 1964 Amphicar in 2000, the Guinness World Record Python in 2010, the globally celebrated Panther in 2014, and now the world's most advanced production amphibious vehicle: the WaterCar EV.

Every WaterCar EV is precision-engineered and hand-assembled at our facility in Fountain Valley, California. Your vehicle has been individually inspected and tested before delivery. We take immense pride in what we build, and we stand behind it completely.

Please take time to read this manual completely before operating your WaterCar EV. If you were unable to visit our facility in Fountain Valley, California before taking delivery, please be aware that hands-on orientation at our factory is strongly recommended and may be required depending on your boating experience level. Operating the WaterCar EV — particularly on water — requires a skill set that differs from both conventional vehicles and conventional boats. Do not get frustrated: depending on your level of boating experience, water operation may be easier for some than others. If you encounter challenges, a visit to our facility for in-person training may be required even after purchase. You are always welcome to visit us for additional training at any time. Boating training and experience are essential for safe water operation of this vehicle. Understanding your vehicle fully will maximize your enjoyment and ensure you operate it safely, legally, and with confidence in every mode — on the road, on the water, and in the transition between the two.

1.2 About the WaterCar EV

The WaterCar EV is a fully amphibious vehicle that operates in two completely independent modes:

- LSV Road Mode — powered by a 48V LiFePO4 electric drive system (ProDrive™), certified as a Low Speed Vehicle (LSV) under 49 CFR Part 571.500 (FMVSS 500), road-legal up to 25 MPH on public roads with posted speed limits of 35 MPH or less.
- Marine Water Mode — powered by a Mercury® outboard engine, NMMA-certified as a motorized recreational vessel, registered and regulated under U.S. Coast Guard authority.

A patented hydraulic wheel system (LaunchMode™) allows the vehicle to transition between modes at the water's edge. No trailer, crane, or external equipment is required. The WaterCar EV is its own launch and retrieval platform.

1.3 How to Use This Manual

This manual is organized into self-contained sections by operating mode. If you have purchased the LSV-only configuration, Sections 1–4 and 7 apply to your vehicle. If you have purchased the Marine Package, all sections apply. Section 6 — Amphibious Operation — requires familiarity with both Sections 4 and 5 before reading.

Section	Topic	Applies To
1	Introduction & Welcome	All
2	Safety Information & Labels	All
3	Battery Systems	All
4	LSV Road Operation	All
5	Marine Water Operation	Marine Package only
6	Amphibious Operation	Marine Package only
7	Care & Maintenance	All
Appendices	Delivery, Legal, Warranty	All

1.4 WaterCar Contact Information

Contact	Details
Direct Line	(714) 251-6687 — Sales/Service Department
Email	info@watercar.com
Website	www.watercar.com
Address	17403 Newhope St., Fountain Valley, CA 92708
Instructional Video	https://www.youtube.com/watch?v=wdKs5TyZWGE
Label & Parts Orders	info@watercar.com — reference your VIN

NOTICE

WaterCar provides direct, real-time remote support via phone and video for all owners worldwide. Most service questions are resolved remotely. Call or text the Sales/Service Department at (714) 251-6687 for any operational or service question.

SECTION 2

Safety Information & Labels

2. Safety Information & Labels

2.1 Safety Alert Definitions

The following alert levels are used throughout this manual. Read and understand each level before operating.

Level	Meaning
⚠ DANGER	Indicates a hazardous situation which, if not avoided, WILL result in death or serious injury.
⚠ WARNING	Indicates a hazardous situation which, if not avoided, COULD result in death or serious injury.
⚠ CAUTION	Indicates a hazardous situation which, if not avoided, could result in minor or moderate injury.
⚠ NOTICE	Indicates a potentially hazardous situation which, if not avoided, may result in property damage.

2.2 Owner / Operator Responsibilities

Requirement	Details
READ FIRST	READ THIS MANUAL AND ALL LABELS CAREFULLY BEFORE OPERATING.
INSPECT	INSPECT THE VEHICLE EACH TIME BEFORE USE.
MAINTENANCE	FOLLOW ALL INSPECTION AND MAINTENANCE PROCEDURES IN THIS MANUAL.
LIMITATIONS	UNDERSTAND AND NEVER EXCEED THE VEHICLE'S LIMITATIONS.
LAWS	COMPLY WITH ALL APPLICABLE FEDERAL, STATE, AND LOCAL LAWS.
LICENSED DRIVER	NEVER ALLOW ANYONE WITHOUT A VALID DRIVER'S LICENSE TO OPERATE ON LAND.
SEAT BELTS	ENSURE ALL SEAT BELTS ARE SECURED BEFORE OPERATING.
CAPACITY	NEVER EXCEED THE MAXIMUM OCCUPANT CAPACITY.
GVWR	NEVER EXCEED THE GROSS VEHICLE WEIGHT RATING.
ROLLOVER	THE CAB FRAME IS NOT DESIGNED TO PROVIDE ROLLOVER PROTECTION. AVOID ROLLOVER SITUATIONS.
NO MODIFICATIONS	NEVER MODIFY WITH NON-APPROVED PARTS OR ACCESSORIES.
ELECTRICAL HAZARD	THE BATTERY VOLTAGE IS SUFFICIENT TO CAUSE DEATH. NEVER SERVICE THE ELECTRIC DRIVE SYSTEM UNLESS PROPERLY TRAINED.

ACCESSORIES	NEVER GROUND ANY ACCESSORY DIRECTLY TO THE VEHICLE CHASSIS. CONNECT ONLY TO THE DESIGNATED ACCESSORY TERMINAL BOARD.
PARK BRAKE	ALWAYS SET THE PARK BRAKE AND REMOVE THE KEY WHEN LEAVING THE VEHICLE UNATTENDED.
ACCIDENT	ALWAYS HAVE THE VEHICLE INSPECTED BY AN AUTHORIZED TECHNICIAN AFTER ANY ACCIDENT.
PASSENGERS	DO NOT CARRY A PASSENGER UNTIL YOU HAVE AT LEAST TWO HOURS OF DRIVING EXPERIENCE WITH THIS VEHICLE.
STAY SOBER	NEVER OPERATE UNDER THE INFLUENCE OF DRUGS OR ALCOHOL.
BOATING EXPERIENCE	THE WATERCAR EV REQUIRES PRIOR BOATING EXPERIENCE FOR MARINE OPERATION. DO NOT OPERATE ON WATER WITHOUT PRIOR BOATING PROFICIENCY.

2.3 GVWR, GAWR & Payload Capacity

These ratings apply to all WaterCar EV configurations regardless of operating mode.

⚠ WARNING

THE GROSS VEHICLE WEIGHT RATING (GVWR) OF YOUR WATERCAR EV IS 2,995 POUNDS. THIS IS THE MAXIMUM ALLOWABLE TOTAL WEIGHT INCLUDING THE VEHICLE ITSELF, PASSENGERS, CARGO, AND ACCESSORIES. NEVER EXCEED THE GVWR.

⚠ WARNING

THE GROSS AXLE WEIGHT RATING (GAWR) IS THE MAXIMUM PERMISSIBLE WEIGHT THAT CAN BE SUPPORTED BY A SINGLE AXLE. NEVER LOAD THE VEHICLE IN A WAY THAT PUTS EXCESSIVE WEIGHT ON EITHER AXLE. DISTRIBUTE CARGO AND PASSENGERS EVENLY.

Item	Value
GVWR	2,995 lbs / 1,356 kg
Curb Weight — LSV Package (est.)	Approx. 2,000 lbs — confirm on VIN plate
Available Payload (est.)	995 lbs
Maximum Occupants — Road	4 persons
Maximum Occupants — Water	4 persons / 850 lbs (see capacity plate, Section 5.5)

Occupant Seating Positions

Vehicle Occupant Positions on Street

Vehicle Occupant Positions on Street

- **Maximum is (4) on street**

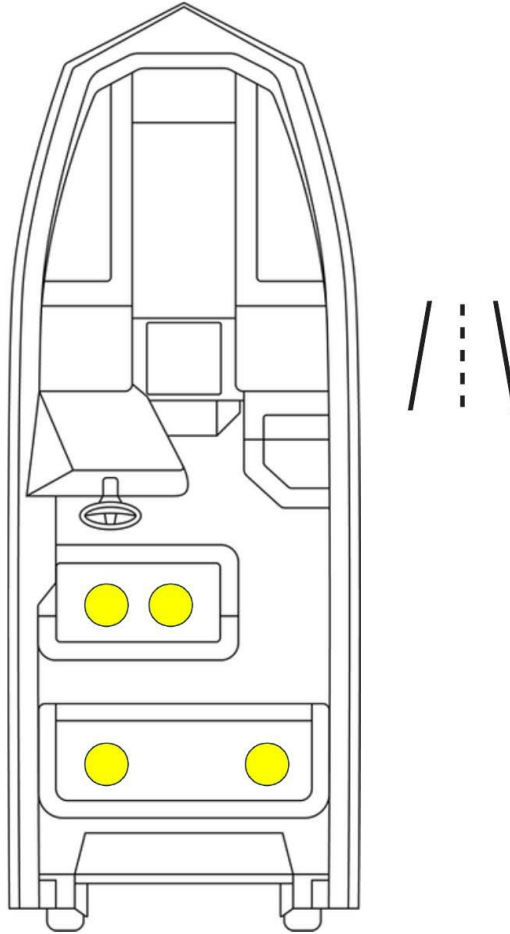

Boat Occupant Positions on Water

- Limit is (4) occupants
- Maximum is 850 lbs on water

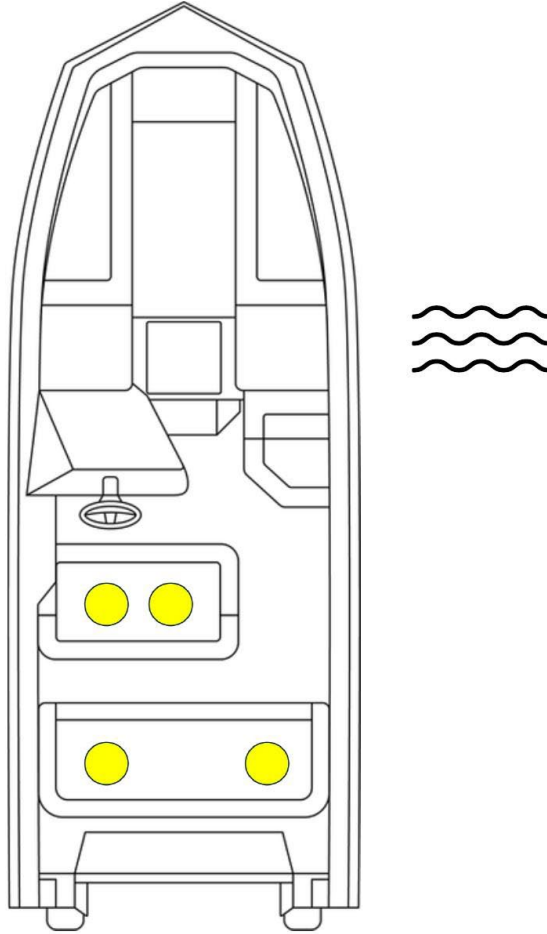

Non-Passenger Seating Areas

THESE AREAS ARE NOT DESIGNED FOR PASSENGER SEATING WHILE THE VEHICLE IS IN MOTION ON LAND OR WATER. REMAIN SEATED ONLY IN DESIGNATED SEATING POSITIONS.

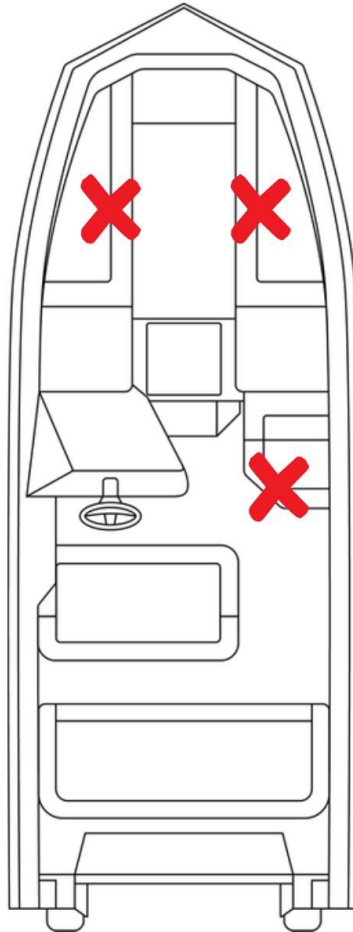

2.4 Seat Belt Use & Inspection

This vehicle is equipped with 2-point lap seat belts. Always make sure seat belts are secured for the operator and all passengers before operating on land.

⚠ WARNING

Always wear your seat belt during road operation. Failure to wear a seat belt may result in serious injury or death. Position the lap belt low across the hips, not across the abdomen.

1. Push the latch plate into the buckle until it clicks securely.
2. Press the release button to confirm the belt releases freely.
3. Pull each belt fully and inspect for cuts, wear, fraying, or stiffness.
4. If any damage is found, do not operate until the seat belt is replaced.
5. To clean: sponge with mild soap and water. Do not use bleach, dye, or household detergents.

Seat Belt Fitting Instructions

This vehicle is equipped with 2-point lap seat belts designed to distribute the force of a collision across the pelvic bones, which are better suited to absorb impact than the abdomen.

To properly fit and secure the seat belt:

- Locate the seat belt for your seating position. Each seat is equipped with a belt.
- Grasp the metal latch plate and pull the seat belt across your body. Ensure the belt is not twisted.
- Position the lap belt LOW across your hips, NOT across your stomach. This distributes impact force across the pelvic bones.
- Insert the metal latch plate into the buckle until you hear a distinct click. Tug gently to confirm it is securely fastened.
- Adjust for comfort if necessary. The belt should be snug but not restrictive.
- Before starting the vehicle, verify that all occupants have properly fitted and secured seat belts.

Consistent use of seat belts is one of the most effective measures to protect yourself and your passengers. Adhering to these instructions significantly reduces the risk of injury during road operation.

2.5 Battery Safety

⚠ DANGER

Do NOT charge indoors without ventilation or near open flames. Always charge in a well-ventilated area free of flammable materials. Do not charge with a damaged cord or connector. Use only approved chargers. See Section 3. Failure to follow charging instructions may result in FIRE, SERIOUS INJURY, OR DEATH.

2.6 Equipment Modifications

Never install any accessory that grounds to the vehicle chassis. Do not install any non-approved accessory or modify the vehicle, including for the purpose of increasing speed or power.

⚠ WARNING

The addition of certain accessories may change the handling characteristics of the vehicle and affect GVWR compliance. Use only WaterCar-approved accessories.

2.7 Hot Components & Exhibition Driving

Hot Drive System Components

The electric motor, Curtis® controller, and associated drive system components become very hot during and after use of the vehicle. Hot components can cause burns and create a fire risk if combustible materials come into contact with them.

⚠ WARNING

Do not touch drive system components after use — allow them to cool. Always keep combustible materials away from the drive system. Use caution when operating near dry grass, brush, leaves, or other flammable debris. Inspect the vehicle for any debris clinging near the drive system after use and remove it promptly.

Exhibition Driving & Improper Operation

The WaterCar EV is designed for normal road and water operation at or below its rated speeds. It is not designed for stunts, exhibition driving, or aggressive maneuvers. Improper operation increases the risk of accident, rollover, or loss of control.

⚠ WARNING

Never attempt wheelies, jumps, doughnuts, or other stunts. Never turn abruptly or at sharp angles at speed. Never operate at excessive speeds for the conditions. Never operate while under the influence of alcohol, drugs, or medication. Never leave the key in the vehicle when unattended — this could result in unauthorized use by someone without a valid driver's license. After any rollover or accident, have the vehicle inspected by a qualified service technician before returning to operation.

2.8 Safety Labels — Complete Reference

Before operating your vehicle, ensure that you and all operators have read, understood, and complied with every label and decal affixed to the WaterCar EV. These safety labels contain critical information regarding operation, maintenance, and hazard awareness. They are designed to reduce the risk of injury, damage, or unsafe operation by alerting the operator to specific dangers and reminding users of essential precautions.







All labels are considered part of the vehicle's safety system and must remain clean, legible, and securely attached at all times. Never modify, cover, or remove a label for any reason. If a label becomes damaged, unreadable, or missing, it must be replaced immediately before further operation.

Labels are placed in specific locations on the vehicle to provide warnings near relevant components or operating controls. Refer to the diagrams in this section for the locations of all required labels. Replacement labels identical to the originals can be ordered directly from WaterCar Corporate Headquarters. Use only genuine WaterCar labels to maintain compliance with federal and marine safety standards.

⚠ WARNING

Failure to follow the warnings or instructions provided on these labels — or to replace missing or illegible labels — may result in serious injury, death, or property damage. WaterCar Inc. assumes no responsibility for accidents, injuries, or damage resulting from the removal, alteration, or disregard of any safety label or warning decal.

Vehicle Safety Labels







<p>LOW SPEED VEHICLE DISCLOSURE Location: Center Port Beneath Control Panel</p>	<div style="border: 1px solid black; padding: 10px;"> <p style="text-align: center;">Low Speed Vehicle Disclosure</p> <p style="text-align: center;">This vehicle is classified as a low speed vehicle</p> <p>This vehicle:</p> <ul style="list-style-type: none"> • Has a maximum speed of greater than 20 miles per hour, but not greater than 25 miles per hour; • May be a hazard on the roadways if it impedes traffic; • May subject the driver to citations for impeding traffic; • May not be equipped with such safety features as bumpers, a padded dashboard, visors, and a tamper-resistant odometer; • May be subject to other restrictions specific to the state or local jurisdiction in which it is operated; and • Shall not be operated on a public highway with a speed limit in excess of the maximum specified by the state or local jurisdiction in which it is operated, including: <ul style="list-style-type: none"> ◦ NY: Shall not be operated on a public highway with a speed limit in excess of 35 miles per hour. ◦ MD and IL: Shall not be operated on a public highway with a speed limit in excess of 30 miles per hour. </div>			
<p>WARNING: GENERAL USE — OPERATING RULES Location: Center Port Beneath Control Panel</p>	<div style="border: 1px solid black; padding: 10px;"> <p style="text-align: center;">WARNING</p> <ul style="list-style-type: none"> • Read your Owner's Manual before operating this vehicle. • Do not operate this vehicle under the influence of alcohol, drugs, or medication. • Although most states prohibit this vehicle from operation on streets having posted speed limits of more than thirty-five miles per hour (35 mph), state and local rules may vary. Check with your local law enforcement (city and state officials) for validation in your area. • This vehicle is not intended to be driven at more than twenty-five miles per hour (25 mph). • Never exceed the passenger and cargo limits of this vehicle. • Do not start or operate vehicle until all occupants are seated with seat belts fastened. • Keep arms and legs inside vehicle at all times. • Avoid sharp turns on inclines and at high speeds (may cause rollover). • Reduce speed on wet and slippery surfaces and in turns. • Do not leave children unattended in vehicle. • Set handbrake before leaving the vehicle. • Remove key when leaving vehicle unattended. • Stop vehicle before reversing direction. • Be aware of small children and objects behind you before reversing. <p style="text-align: center; font-size: small;">ALWAYS DRIVE SAFELY. FAILURE TO FOLLOW THESE WARNINGS COULD RESULT IN SERIOUS OR FATAL INJURY.</p> </div>			
<p>WARNING: ROLLOVER RISK & SEATBELT WARNING Location: Center Port Beneath Control Panel</p>	<div style="border: 1px solid black; padding: 10px;"> <p style="text-align: center;">WARNING</p> <table border="1" style="width: 100%; text-align: center;"> <tr> <td style="width: 33%;"></td> <td style="width: 33%;">ROLLOVER RISK Avoid abrupt maneuvers and excessive speed. Always buckle up. <small>See Owner's Manual for further information</small></td> <td style="width: 33%;"></td> </tr> </table> </div>		ROLLOVER RISK Avoid abrupt maneuvers and excessive speed. Always buckle up. <small>See Owner's Manual for further information</small>	
	ROLLOVER RISK Avoid abrupt maneuvers and excessive speed. Always buckle up. <small>See Owner's Manual for further information</small>			
<p>WARNING: SEAT BELTS REQUIRED WHILE ON LAND Location: Dash / Center Port Panel</p>	<div style="border: 1px solid black; padding: 10px;"> <p style="text-align: center;">WARNING</p> <p style="text-align: center;">SEAT BELTS REQUIRED WHILE ON LAND</p> <p style="text-align: center;">Failure to wear seat belts may result in serious injury or death</p> </div>			
<p>WARNING: REMAIN FULLY SEATED AND HOLD ON Location: Cockpit Interior</p>	<div style="border: 1px solid black; padding: 10px;"> <p style="text-align: center;">WARNING</p> <p style="text-align: center;">Remain fully seated and hold on when in motion. Keep entire body inside vehicle</p> </div>			





<p>DANGER: THESE ARE NOT PASSENGER SEATS Location: Non-Designated Seating Areas</p>	<div style="border: 1px solid black; padding: 5px;"> <div style="background-color: red; color: white; text-align: center; padding: 5px;"> DANGER </div> <p style="text-align: center;">THESE ARE NOT PASSENGER SEATS WHILE VEHICLE IS IN MOTION Do not stand, ride, or sit in this area while vehicle is in motion. Serious injury or death may result. Use designated seats only.</p> </div>
<p>PARKING BRAKE RELEASE / DIRECTIONAL SWITCH Location: Parking Brake Area / Dash</p>	<div style="border: 1px solid black; padding: 10px; text-align: center;"> <p>Parking Brake Release button</p> <p>Directional Switch Must be in <u>Neutral</u></p> </div>

Boat Safety Labels

<p>DANGER: MOVING PROPELLERS / CARBON MONOXIDE Location: Center Port Beneath Outboard F/R Shifter</p>	<div style="border: 1px solid black; padding: 5px;"> <div style="background-color: red; color: white; text-align: center; padding: 5px;"> DANGER </div> <table border="1" style="width: 100%; border-collapse: collapse;"> <tr> <td style="width: 50%; text-align: center; vertical-align: middle;"> </td> <td style="width: 50%; padding: 5px;"> <p>CONTACT WITH A SPINNING PROPELLER WILL CAUSE SERIOUS INJURY OR DEATH.</p> <p>STAY CLEAR OF BOAT AND STAY OFF SWIM PLATFORM AND BOARDING LADDER WHILE ENGINE IS RUNNING.</p> <p>SHUT OFF ENGINES WHILE PEOPLE ARE IN THE WATER NEAR THE BOAT, ON THE SWIM PLATFORM, OR ON THE BOARDING LADDER.</p> </td> </tr> <tr> <td style="width: 50%; text-align: center; vertical-align: middle;"> </td> <td style="width: 50%; padding: 5px;"> <p>CARBON MONOXIDE (CO) CAN CAUSE BRAIN DAMAGE OR DEATH.</p> <ul style="list-style-type: none"> • Engine and generator exhaust contains odorless and colorless carbon monoxide gas. • Carbon monoxide will be around the back of the boat when engines or generators are running. <p>MOVE TO FRESH AIR if you feel nausea, headache, dizziness, or drowsiness.</p> </td> </tr> </table> </div>		<p>CONTACT WITH A SPINNING PROPELLER WILL CAUSE SERIOUS INJURY OR DEATH.</p> <p>STAY CLEAR OF BOAT AND STAY OFF SWIM PLATFORM AND BOARDING LADDER WHILE ENGINE IS RUNNING.</p> <p>SHUT OFF ENGINES WHILE PEOPLE ARE IN THE WATER NEAR THE BOAT, ON THE SWIM PLATFORM, OR ON THE BOARDING LADDER.</p>		<p>CARBON MONOXIDE (CO) CAN CAUSE BRAIN DAMAGE OR DEATH.</p> <ul style="list-style-type: none"> • Engine and generator exhaust contains odorless and colorless carbon monoxide gas. • Carbon monoxide will be around the back of the boat when engines or generators are running. <p>MOVE TO FRESH AIR if you feel nausea, headache, dizziness, or drowsiness.</p>
	<p>CONTACT WITH A SPINNING PROPELLER WILL CAUSE SERIOUS INJURY OR DEATH.</p> <p>STAY CLEAR OF BOAT AND STAY OFF SWIM PLATFORM AND BOARDING LADDER WHILE ENGINE IS RUNNING.</p> <p>SHUT OFF ENGINES WHILE PEOPLE ARE IN THE WATER NEAR THE BOAT, ON THE SWIM PLATFORM, OR ON THE BOARDING LADDER.</p>				
	<p>CARBON MONOXIDE (CO) CAN CAUSE BRAIN DAMAGE OR DEATH.</p> <ul style="list-style-type: none"> • Engine and generator exhaust contains odorless and colorless carbon monoxide gas. • Carbon monoxide will be around the back of the boat when engines or generators are running. <p>MOVE TO FRESH AIR if you feel nausea, headache, dizziness, or drowsiness.</p>				
<p>DANGER: DO NOT CONNECT TO SHORE POWER WHILE VESSEL IS IN WATER Location: Charger Hatch Cover on Starboard Side</p>	<div style="border: 1px solid black; padding: 5px;"> <div style="background-color: red; color: white; text-align: center; padding: 5px;"> DANGER </div> <p style="text-align: center;">Do NOT connect to shore power while vessel is in water. Failure to follow this instruction may result in FIRE, ELECTRICAL SHOCK, OR DEATH.</p> </div>				
<p>DANGER: ATTACH ENGINE SHUT-OFF LANYARD Location: Helm / Transom Area</p>	<div style="border: 1px solid black; padding: 5px;"> <div style="background-color: red; color: white; text-align: center; padding: 5px;"> DANGER </div> <p style="text-align: center;">Attach engine shut-off lanyard to operator before starting engine. Failure to do so may result in serious injury or death.</p> </div>				

<p>DANGER: NOT DESIGNED FOR SURF CONDITIONS Location: Hull Exterior / Helm Console</p>	<div style="border: 2px solid black; padding: 10px;"> <div style="background-color: red; color: white; text-align: center; padding: 5px;"> DANGER </div> <p>NOT DESIGNED FOR SURF CONDITIONS</p> <p>This vessel is not designed for operation in breaking waves or surf zones. Do NOT operate in breaking waves. Do NOT launch or recover through surf. Breaking waves can cause sudden loss of control, swamping, or capsize.</p> <p>Serious injury or death could result.</p> </div>		
<p>DANGER: WATER ENTRY / EXIT PROCEDURE Location: Helm Console</p>	<div style="border: 2px solid black; padding: 10px;"> <div style="background-color: red; color: white; text-align: center; padding: 5px;"> DANGER </div> <p>WATER ENTRY / EXIT PROCEDURE Water entry and exit may result in loss of control. Serious injury or death could result.</p> <table border="0" style="width: 100%;"> <tr> <td style="vertical-align: top; width: 50%;"> <p>BEFORE ENTERING WATER:</p> <ul style="list-style-type: none"> • Drain plug installed and secured. • All hatches and doors fully closed and latched. • Bilge pump operational. • Life jackets worn. Engine lanyard attached. • Do NOT engage marine propulsion unless vessel is floating freely. </td> <td style="vertical-align: top; width: 50%;"> <p>BEFORE EXITING WATER:</p> <ul style="list-style-type: none"> • Inspect shoreline and exit path for drop-offs, soft sand, obstacles, and submerged hazards. • Approach shore at idle speed. • Deploy wheels fully and confirm locked in land position before applying throttle. • Do NOT operate marine propulsion out of water. </td> </tr> </table> <p style="color: red; text-align: center;">Water entry and exit conditions vary by location. The operator is responsible for safe operation.</p> </div>	<p>BEFORE ENTERING WATER:</p> <ul style="list-style-type: none"> • Drain plug installed and secured. • All hatches and doors fully closed and latched. • Bilge pump operational. • Life jackets worn. Engine lanyard attached. • Do NOT engage marine propulsion unless vessel is floating freely. 	<p>BEFORE EXITING WATER:</p> <ul style="list-style-type: none"> • Inspect shoreline and exit path for drop-offs, soft sand, obstacles, and submerged hazards. • Approach shore at idle speed. • Deploy wheels fully and confirm locked in land position before applying throttle. • Do NOT operate marine propulsion out of water.
<p>BEFORE ENTERING WATER:</p> <ul style="list-style-type: none"> • Drain plug installed and secured. • All hatches and doors fully closed and latched. • Bilge pump operational. • Life jackets worn. Engine lanyard attached. • Do NOT engage marine propulsion unless vessel is floating freely. 	<p>BEFORE EXITING WATER:</p> <ul style="list-style-type: none"> • Inspect shoreline and exit path for drop-offs, soft sand, obstacles, and submerged hazards. • Approach shore at idle speed. • Deploy wheels fully and confirm locked in land position before applying throttle. • Do NOT operate marine propulsion out of water. 		
<p>WARNING: VISIBILITY FROM HELM STATION IS LIMITED Location: Helm Console</p>	<div style="border: 2px solid black; padding: 10px;"> <div style="background-color: orange; text-align: center; padding: 5px;"> WARNING </div> <p>Visibility from this helm station is limited. Avoid serious injury or death from collisions. Maintain lookout as required by USCG Navigation Rules.</p> <p style="text-align: center;">Read owner's manual.</p> </div>		
<p>WARNING: READ OWNER'S MANUAL BEFORE TOWING OR USING BOAT Location: Helm Area</p>	<div style="border: 2px solid black; padding: 10px;"> <div style="background-color: orange; text-align: center; padding: 5px;"> WARNING </div> <p style="text-align: center;">IT IS ABSOLUTELY NECESSARY THAT YOU READ, UNDERSTAND, AND FOLLOW ALL INFORMATION AND INSTRUCTIONS IN THE OWNER'S MANUAL PRIOR TO TOWING OR USING THIS BOAT.</p> </div>		

<p>WARNING: LEAKING FUEL — FIRE / EXPLOSION RISK Location: Fuel Fill</p>	<div style="border: 1px solid black; padding: 5px;"> <p style="text-align: center;"> WARNING</p> <p>Avoid serious injury or death from fire or explosion from leaking fuel. Contents can be under pressure. Open slowly in well ventilated area. No smoking or open flames. Check for leaks at least once a year.</p> </div>
<p>WARNING: GASOLINE IS HIGHLY FLAMMABLE AND EXPLOSIVE Location: Fuel Fill</p>	<div style="border: 1px solid black; padding: 5px;"> <p style="text-align: center;"> WARNING</p> <p>Gasoline is highly flammable and explosive. A fire or explosion can cause severe injury or death. Shut off engine. Refuel in well ventilated area away from flames or sparks. Do not smoke. Avoid spilling gasoline. Wipe up spilled gasoline immediately.</p> <p style="text-align: center;">UNLEADED REGULAR GASOLINE ONLY</p> </div>
<p>WARNING: HAZARDOUS VOLTAGE — GFCI REQUIRED Location: Charger Hatch Cover on Starboard Side</p>	<div style="border: 1px solid black; padding: 5px;"> <p style="text-align: center;"> WARNING</p> <p>Avoid serious injury or death from fire, explosion, or electrical shock.</p> <ul style="list-style-type: none"> • This device must be connected to a Ground Fault Circuit Interrupt (GFCI) protected AC outlet. • When using an extension cord, connect the AC charger plug before connecting to the GFCI protected AC outlet. • Make connection in an atmosphere free of explosive fumes. • Make cord and connection in a secure manner that will avoid contact with the water. </div>
<p>WARNING: SUDDEN TURNS ABOVE 25 MPH Location: Center Port Beneath Outboard F/R Shifter</p>	<div style="border: 1px solid black; padding: 5px;"> <p style="text-align: center;"> WARNING</p> <p>SUDDEN TURNS ABOVE 25MPH MAY CAUSE LOSS OF BOAT CONTROL, WHICH COULD RESULT IN SERIOUS INJURY OR DEATH. REDUCE SPEED BEFORE ATTEMPTING A SUDDEN SHARP TURN. READ OWNER'S MANUAL FOR ADDITIONAL INFORMATION</p> </div>
<p>WARNING: ETHANOL CONTENT — DO NOT EXCEED 10% Location: Fuel Fill Area</p>	<div style="border: 1px solid black; padding: 5px;"> <p style="text-align: center;"> WARNING</p> <p>GASOLINE CONTAINING MORE THAN 10% ETHANOL (E10) CAN DAMAGE YOUR ENGINE AND FUEL SYSTEM. DO NOT USE FUEL WITH MORE THAN 10% ETHANOL. USING IMPROPER FUEL CAN CAUSE ENGINE DAMAGE AND VOID YOUR WARRANTY.</p> </div>
<p>WARNING: INSPECT BILGE PUMP BEFORE WATER ENTRY Location: Helm / Bilge Area</p>	<div style="border: 1px solid black; padding: 5px;"> <p style="text-align: center;"> WARNING</p> <p>Inspect bilge pump before water entry. Keep intake clear. Monitor water level. Return to shore immediately if pump runs continuously or water level rises. Failure may result in serious injury or death.</p> </div>

<p>WARNING: KEEP DOOR CLOSED — RISK OF FLOODING OR EJECTION Location: Door / Side Panel</p>	<div style="border: 1px solid black; padding: 10px; text-align: center;">  WARNING KEEP DOOR CLOSED RISK OF FLOODING OR EJECTION </div>
<p>WARNING: MAKE SURE DASH HATCH IS SECURELY SHUT Location: Dash Hatch Area</p>	<div style="border: 1px solid black; padding: 10px; text-align: center;">  WARNING MAKE SURE DASH HATCH IS SECURELY SHUT INSPECT FOR LEAKS </div>
<p>WARNING: BATTERY COMPARTMENT HATCH MUST REMAIN CLOSED Location: Battery Compartment Hatch</p>	<div style="border: 1px solid black; padding: 10px; text-align: center;">  WARNING BATTERY COMPARTMENT HATCH MUST REMAIN CLOSED INSPECT FOR WATER IN BATTERY COMPARTMENT PRIOR TO EACH USE </div>
<p>WARNING: TOW POINT — WATER SPORTS USE ONLY Location: Transom Tow Point</p>	<div style="border: 1px solid black; padding: 10px; text-align: center;">  WARNING Tow point failure can result in serious injury or death. Do not attach inflatables, toys or vessels to this tow point. Only use this water sports tow point for wake board, and wake surfing. </div>
<p>BOATING CHECKLIST — PRE-OPERATION INSPECTION Location: Helm Area / Cockpit</p>	<div style="border: 1px solid black; padding: 10px;"> <p style="text-align: center;">Boating Checklist</p> <p style="text-align: center;">Pre-Operation Inspection</p> <p style="text-align: center;">CHECK BEFORE YOU LAUNCH YOUR BOAT:</p> <ul style="list-style-type: none"> • Read and understand the Owner's Manual • Drain plug in (installed correctly) • Battery charged, battery box tight and secured, not freely moving in bilge • No water in battery compartment • Steering works properly, moves smoothly and properly; self-centers when in place • Battery cables in place, cable terminals clean and tight • Sufficient fuel (check gauge, visually check tank, fill if necessary) • Work all controls for free, full movement • All required safety equipment on board (check bilge area for gas vapors, look for fuel or oil leaks) • Safety equipment on board: fire extinguisher, paddle, anchor, horn, whistle, distress signals (flares, flag, etc.), throwable flotation device, life jackets, bailer, etc. • Safety equipment in working order (fire extinguisher, bailer, etc.) • Engine compartment (if equipped) is free of fuel vapors • Load boat properly: distribute weight evenly (persons, gear, etc.) • Advise each passenger of location of emergency equipment • Leave float plan with responsible person (relative or friend) <p style="text-align: center;">CHECK BEFORE YOU START YOUR ENGINE:</p> <ul style="list-style-type: none"> • Fuel (sufficient for trip, check bilge and/or gas odor) • Control in neutral • Ventilate (open engine compartment cover if equipped) • Personal flotation devices (on occupants) • Safety lanyard (lanyard properly clipped on operator) • Engine area (inspect bilge for leaks; check fuel line connections) • Loading (weight properly distributed, gear secured) • Seat/seat supports in place (properly secured) • Lanyard stop switch operational • Keep a firm and continuous grip on the steering wheel </div>

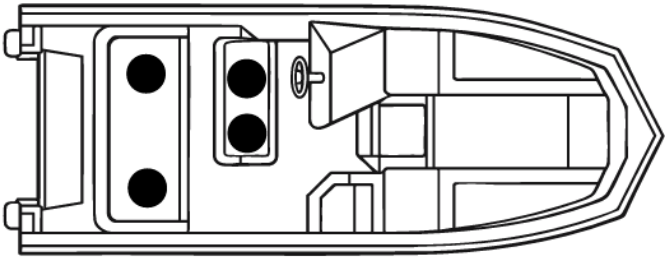
<p>RECOMMENDED SEATING LOCATIONS ON WATER Location: Cockpit Interior</p>	<div style="border: 2px solid black; padding: 10px; text-align: center;"> <p>RECOMMENDED SEATING LOCATIONS AT BOAT SPEEDS GREATER THAN 5MPH ON WATER</p>  </div>
<p>SHIPPING REMINDER — TURN OFF BOTH BATTERIES Location: Transport Reminder Panel</p>	<div style="border: 2px solid black; padding: 5px; background-color: #f9a825; color: white;"> <p style="text-align: center;">⚠ SHIPPING REMINDER</p> <p style="text-align: center; font-size: small;">TURN OFF BOTH BATTERIES BEFORE TRANSPORT</p> <p style="text-align: center; font-size: x-small;">This vehicle is equipped with two batteries (12V and 48V) located under the center floor hatch. To access: Open center floor hatch. ON/OFF buttons are located on each battery. Ensure both batteries are OFF before shipping or transport.</p> </div>

⚠ CAUTION

Do not remove or obstruct any safety label. Replace any label which becomes illegible. Replacement labels can be ordered from WaterCar Corporate Headquarters.

2.9 Safety Label Location Summary

Label / Decal	Level	Location
Boating Checklist — Pre-Operation Inspection	INFO	Helm area / cockpit
DANGER: Do NOT connect to shore power while vessel is in water	DANGER	Helm / charge port vicinity
12 Volt Battery ON/OFF	INFO	Battery compartment hatch
48 Volt Battery ON/OFF	INFO	Battery compartment hatch
WARNING: Visibility from helm station is limited	WARNING	Helm console
WARNING: Seat Belts Required While on Land	WARNING	Dash / center port panel
WARNING: Read Owner's Manual before towing or using boat	WARNING	Helm area
WARNING: Inspect bilge pump before water entry	WARNING	Helm / bilge area
WARNING: Make sure dash hatch is securely shut	WARNING	Dash hatch area
WARNING: Risk of Flooding or Ejection — Keep Door Closed	WARNING	Door / side panel

WARNING: Keep entire body inside vehicle when in motion	WARNING	Cockpit interior
WARNING: Sudden turns above 25 MPH may cause loss of control	WARNING	Helm console
WARNING: Gasoline more than 10% ethanol will damage engine	WARNING	Fuel fill area
WARNING: Tow point — water sports use only	WARNING	Transom tow point
WARNING: Battery compartment hatch must remain closed	WARNING	Battery compartment hatch
BATTERY COMPARTMENT (location marker)	INFO	Battery hatch / access panel
GREASE ZERKS REGULARLY LOCATED HERE	INFO	Hydraulic pivot points
HYDRAULIC PUMPS LOCATED HERE	INFO	Hydraulic pump access
12V FUSE LOCATED HERE	INFO	12V fuse panel
PARKING BRAKE MANUAL RELEASE	INFO	Parking brake area
48V FUSE LOCATED HERE	INFO	48V fuse panel
DANGER: These are not passenger seats while vehicle is in motion	DANGER	Non-designated seating areas
Recommended Seating Locations at boat speeds greater than 5 MPH	INFO	Cockpit interior
WARNING: Fuel system — fire or explosion from leaking fuel	WARNING	Fuel system access
Parking Brake Release Button (label)	INFO	Parking brake lever area
Directional Switch — Must be in Neutral (label)	INFO	FNR switch area
DANGER: Attach engine shut-off lanyard before starting engine	DANGER	Helm / ignition area
QR Code: Scan to download User Manual — WaterCar.com/owner	INFO	Battery compartment / dash
DANGER: Contact with spinning propeller will cause serious injury or death	DANGER	Transom / stern
DANGER: Carbon Monoxide can cause brain damage or death	DANGER	Transom / stern
FIRE EXTINGUISHER ON BOARD (location marker)	INFO	Fire extinguisher mounting area
WARNING: GFCI charging — fire, explosion, electrical shock	WARNING	Charging port area
SHIPPING REMINDER: Turn off both batteries before transport	INFO	Battery compartment / transport
Low Speed Vehicle Disclosure (full legal text)	LEGAL	Center port, beneath control panel

WARNING: LSV operational warnings (full text)	WARNING	Center port, beneath control panel
UNLEADED REGULAR GASOLINE ONLY	INFO	Fuel fill cap area
DANGER: Water Entry / Exit Procedure	DANGER	Helm console
WARNING: Dual Battery System — 12V and 48V	WARNING	Battery compartment / dash
WARNING: Rollover Risk	WARNING	Non-passenger seating areas
DANGER: Not Designed for Surf Conditions	DANGER	Exterior hull / transom

SECTION 3**Battery Systems**

48V Eco Battery® Gen3 • 12V Epoch DP12120H

3. Battery Systems

The WaterCar EV uses two independent battery systems that must both be operational for normal vehicle function. Understanding both systems is essential before operating in any mode.

3.1 Dual Battery System Overview

System	Specification	Function
48V Drive Battery	Eco Battery® Gen3 LiFePO4 — 160Ah / 7.68 kWh	Electric land drive system (road propulsion)
12V Auxiliary Battery	Epoch DP12120H LiFePO4 — 120Ah / 1.536 kWh	Outboard ignition, nav lights, accessories, controls
DC-DC Converter	Bidirectional 12V ↔ 48V — up to 900W	Outboard alternator charges drive battery during marine operation
Marine Alternator	Mercury® outboard — 35A / 441W	Charges 12V battery; feeds DC-DC converter during water operation

⚠ WARNING

BOTH battery systems must be powered ON before operating in any mode. Both must be turned OFF before shipping or transport. Failure to follow these instructions may result in battery damage, electrical faults, or fire.

3.2 Battery Performance Tips

- New batteries will not perform to their fullest capacity until they have completed several full discharge and recharge cycles.
- Recharge the batteries after each use. Charge to 100% whenever possible.
- Avoid short charging — disconnecting before the charge cycle completes reduces battery life.
- For best battery life, avoid discharging below 20% state of charge.
- Batteries perform best at room temperature. Do not charge at temperatures above 110°F (43°C).
- Range is affected by road conditions, terrain, temperature, payload, and driving style.
- If the vehicle will not be used for more than 15 days, charge above 50% and turn off the battery.
- Charge at least once every 6 months during long-term storage.

3.3 Cold Weather Operation

Cold weather reduces battery performance and available range for both battery systems.

Condition	Temperature	Effect
48V — Charge cutoff	Below 32°F (0°C)	Battery will NOT accept any charge — including regenerative braking
48V — Shutdown	Below -4°F (-20°C)	Battery automatically shuts down to protect cells
12V — Charge cutoff	Below 32°F (0°C)	Built-in heater activates; warms to 8°C before charging begins
Both — Performance	Any cold temp	Reduced range, slower acceleration, larger voltage drops — normal

⚠ CAUTION

Do not operate the vehicle at speeds that engage regenerative braking when overnight low temperatures are below 32°F (0°C). Regenerative charging at sub-freezing battery temperatures can engage battery self-protection mode and may cause braking system faults.

3.4 Eco Battery — 48V Lithium Gen3

The WaterCar EV primary drive system is powered by an Eco Battery® Gen3 LiFePO4 (Lithium Iron Phosphate) 48-volt battery. LiFePO4 chemistry provides excellent thermal stability and an extended service life compared to other lithium chemistries.

⚠ NOTICE

The Eco Battery® Gen3 unit carries a manufacturer-level ingress protection rating of IP67 when installed in the WaterCar EV sealed battery enclosure. Do not remove or modify the battery enclosure.

⚠ NOTICE

Register your Eco Battery within 60 days of purchase to activate the full warranty. Batteries not registered within 60 days carry a 1-year limited warranty only. Register at: www.ecobattery.com/register

Powering On and Off

- To power ON: Press and hold the button until the green LED illuminates (approximately 1 second), then release. The LED stays illuminated whenever the battery is powered on.
- To power OFF: Press and hold the power button until the LED indicator begins to flash (approximately 3 seconds), then release. The LED will continue to flash until the battery is completely powered down.
- The battery does not need to be turned off after each use. If the vehicle will be unused for longer than 15 days, charge the battery above 50%, disconnect the charger AC power cord, and turn the battery off.

Wake-Up Button

The Remote Wake-Up Button (dash-mounted) powers on or awakens a battery that has entered Power Save Mode. The wake-up button CANNOT turn the battery OFF — it can only turn it ON. To wake a battery in Power Save Mode, simply press and release the wake-up button.

Charging the 48V Battery

⚠ WARNING

DO NOT USE UNAPPROVED BATTERY CHARGERS OR TENDERS. DO NOT CONNECT DC OUTPUT CABLES WITH REVERSE POLARITY. Use only genuine Eco Battery lithium chargers. Battery must be powered ON with the power button illuminated to accept a charge.

6. Connect the DC output ring terminals to the battery terminals.
7. Connect AC input to AC power. All Eco Battery chargers accept 100–250 VAC, single phase, 50 or 60 Hz.
8. Charger LED will blink red when charging and will be solid green when complete.
9. When fully charged, disconnect DC cord from vehicle first, then disconnect AC cord.

Extension cord: Up to 15 ft = 12–14 AWG | 10–25 ft = 10–12 AWG | Over 25 ft = not recommended.

Charge time: Battery Ah ÷ Charger Amps = Hours. Example: 160 Ah ÷ 20A charger = 8 hours.

CAN Communications: The two connectors on the meter cable are CAN communication ports. The Eco Battery system requires 60–120W of resistance on the CAN network. If CAN communication is unstable, add an Eco Battery 120W CAN Resistor Pass-Through (part #A-4209).

SOC Meter Display

Display	Meaning
State of Charge	Displayed in percent. 0% = empty 100% = full
Color — Green	100–50% SOC — Normal operating range
Color — White	49–20% SOC — Plan to charge soon
Color — Red	19–0% SOC — Charge immediately
Battery Current	Discharge = negative. Charging = positive.
Calibration	BMS self-calibrates at end of each full charge cycle. Accuracy +/- 5%.
Sleep Timer	Meter may power off after inactivity. Press wake-up button to activate.
Trouble Codes	Displays DTCs if battery fault detected. Record code and contact WaterCar.

Power Save Mode

The battery automatically enters Power Save Mode after extended periods of inactivity. All LEDs power down completely.

SOC Range	Power Save Activates After
0% – 19%	Several hours of inactivity
20% – 100%	Several days of inactivity

To exit Power Save Mode: Press and release the remote wake-up button or the battery power button.

Heated Battery (Select Configurations)

Select Eco Battery® Gen3 units are equipped with an internal automatic heater. The heater is fully automatic — it activates when the battery charger is plugged in and CAN communication is established. Charging begins once internal temperature reaches 34°C (93°F). No user input is required.

BMS Error Codes

Code	Description	Level	Required Action
E01	MOS Error	1 — Serious	Will not self-resolve. Contact Eco Battery immediately.
E02	External Short Circuit	1 — Serious	Will not self-resolve. Contact Eco Battery immediately.
E03	Cell Differential	1 — Serious	Will not self-resolve. Contact Eco Battery immediately.
E04	Cell Over Voltage	2 — Major	Will self-resolve if conditions allow.
E05	Cell Under Voltage	2 — Major	Will self-resolve if conditions allow.
E06	Pack Over Voltage	2 — Major	Will self-resolve if conditions allow.
E07	Pack Under Voltage	2 — Major	Will self-resolve if conditions allow.
E08	Discharge Over Current	3 — Minor	Will self-resolve if conditions allow.
E09	Charge Over Current	3 — Minor	Will self-resolve if conditions allow.
E10	Discharge Temp High	3 — Minor	Allow battery to cool.
E11	Charge Temp High	3 — Minor	Allow battery to cool before charging.
E12	Charge Temp Low	3 — Minor	Allow battery to warm before charging.
E13	Discharge Temp Low	3 — Minor	Allow battery to warm before use.
E14	MOS Temp High	3 — Minor	Allow system to cool.
E15	SOC Low	3 — Minor	Charge immediately.
E16	External Communication Error	1 — Serious	Will not self-resolve. Contact Eco Battery immediately.
E17	Internal Communication Error	1 — Serious	Will not self-resolve. Contact Eco Battery immediately.

Eco Battery Support: 877-326-2288 | support@ecobattery.com | ecobattery.com

Long-Term Storage — 48V Battery

- For storage longer than 15 days: charge battery above 50%, disconnect charger AC power cord, and turn battery off.
- Charge the battery at least once every 6 months.
- If storing in temperatures below -4°F (-20°C): remove the battery and store above -4°F.
- Do not use non-approved third party battery chargers or tenders.

3.5 Epoch® Battery — 12V Lithium (DP12120H)

The WaterCar EV auxiliary systems and electronics are powered by an Epoch DP12120H Dual-Purpose 12V Lithium Iron Phosphate (LiFePO₄) battery with Smart Monitoring.

Specification	Value — Epoch DP12120H
Chemistry	Lithium Iron Phosphate (LiFePO ₄)
Nominal Voltage	12.8V
Nominal Capacity	120 Ah
Nominal Energy	1,536 Wh
Ingress Protection	IP67 — factory rated
Max Charge Current	100A
Recommended Charge Current	50A
Recommended Charge Voltage	14.4V
Float Voltage	13.6V
Cut-Off Voltage	11.2V
Charge Temperature Range	32°F to 113°F (0°C to 45°C)
Discharge Temperature Range	-4°F to 149°F (-20°C to 65°C)
Cold Weather Heater	Built-in; auto-activates on charge input; warms to 8°C before charging

First Use — Activation Required

10. Place the battery power switch in the ON position.
11. Short-press the reset button for 1 second — SOC LED indicators illuminate for 10 seconds.
12. Long-press and hold the reset button for 10 seconds to activate the battery. After activation, the LED indicators will display battery SOC and the RUN light will flash yellow.

⚠ CAUTION

The battery cannot be used normally until it is activated. BMS self-check on power-on takes up to 10 seconds — do not interrupt power during self-check.

SOC Indicator Lights

SOC Range	Discharge Indication (L1→L4)	Notes
0–25%	Off / Off / Off / Blink	L4 blinks
25–50%	Off / Off / Blink / On	L3 blinks, L4 steady
50–75%	Off / Blink / On / On	L2 blinks, L3–L4 steady
75–100%	Blink / On / On / On	L1 blinks, L2–L4 steady

Charging the 12V Battery

⚠ WARNING

Use only a dedicated lithium battery charger with correct lithium charging settings. Do not use lead-acid chargers. Do not invert the positive and negative terminals.

Specification	Value
Recommended Charge Voltage	14.4V
Float Voltage	13.6V
Recommended Charge Current	50A (0.3C)
Maximum Charge Current	100A (1C)
Cut-Off Voltage	11.2V
Charge Temperature	32°F to 113°F

Routine Maintenance — 12V Battery

- Check battery terminals monthly for corrosion. Clean with baking soda and water if corrosion is found.
- Inspect for physical damage, swelling, or leakage. Do not operate if damage is found — replace immediately.
- Keep the battery area clean and dry. Do not clean with water under pressure.
- Fully charge the battery at least once per month to maintain SOC calibration accuracy.

Storage — 12V Battery

- Store battery at approximately 50% SOC in a dry, clean, well-ventilated environment at 59–95°F (15–35°C).
- For long-term storage: charge the battery every 6 months.
- If the vehicle will be stored for a prolonged period, turn the battery power switch to OFF to minimize self-discharge.
- Reconnect and fully charge before use after any extended storage period.

Epoch Batteries Support: support@epochbatteries.com | www.epochbatteries.com

3.6 Disconnecting and Reconnecting Power (Service)

Disconnecting Power

13. Position the vehicle on a dry, firm, level surface. Set the park brake. Turn the key off.
14. Press and hold the 48V battery power button until the LED begins to flash (~3 sec), then release. Wait for LED to turn off completely.
15. Turn the 12V battery switch to the Off position. Confirm both battery indicators are off before proceeding.

Reconnecting Power

16. Confirm service is complete and all connections are properly secured.
17. Turn the 12V battery switch to the On position.
18. Press and hold the 48V battery power button until the green LED illuminates (~1 sec).

19. Turn the key to the On position and confirm all indicators display normal operating status.

⚠ DANGER

THE BATTERY VOLTAGE IS SUFFICIENT TO CAUSE DEATH BY ELECTROCUTION. ALWAYS FOLLOW THE POWER DISCONNECT PROCEDURE BEFORE PERFORMING ANY SERVICE. NEVER SERVICE THE ELECTRIC DRIVE SYSTEM UNLESS PROPERLY TRAINED.

SECTION 4

LSV Road Operation

Standalone — applies to LSV and Marine Package configurations

4. LSV Road Operation

This section covers all aspects of operating the WaterCar EV as a Low Speed Vehicle (LSV) on public roads. This section is self-contained — LSV-only owners will find everything needed for safe road operation here. Marine Package owners must also read Sections 5 and 6.

4.1 LSV Regulatory Classification

The WaterCar EV is manufactured in conformance with 49 CFR Part 571.500 (Federal Motor Vehicle Safety Standard 500 — Low Speed Vehicles). A 17-character Vehicle Identification Number (VIN) is assigned at manufacture pursuant to 49 CFR Part 565. A Manufacturer's Certificate of Origin (MCO) accompanies each vehicle.

As an LSV, this vehicle is subject to a maximum on-road speed of 25 MPH. Operation on roads with posted speed limits above the applicable state maximum for LSVs is prohibited.

⚠ WARNING

The WaterCar EV is governed to a maximum of 25 MPH in compliance with FMVSS 500. Operation on roadways with posted speed limits above 35 MPH is illegal and extremely dangerous. A valid driver's license is required for all operators.

4.2 Vehicle Identification Number (VIN) Plate

The VIN is located on an aluminum plate affixed under the dash. This plate contains weight ratings including GVWR and GAWR. Always refer to the VIN plate for the authoritative weight data specific to your unit. Record your VIN in the space provided on the Delivery Acknowledgment Form.

MFD BY: WATERCAR INC.		DATE OF MFD: <input type="text"/>	GVWR: 2995 LBS	
FRONT GAWR	WITH TIRES	RIMS AT	COLD	
1438 LBS	27/8.5/R14	14	35 PSI	
REAR GAWR	WITH TIRES	RIMS AT	COLD	
1557 LBS	27/8.5/R14	14	35 PSI	
THIS VEHICLE CONFORMS TO ALL APPLICABLE FEDERAL MOTOR VEHICLE SAFETY STANDARDS IN EFFECT ON THE DATE OF MANUFACTURE SHOWN ABOVE.				
VIN#:	<input type="text"/>			
			TYPE #:	NEV

4.3 Acoustic Vehicle Alerting System (AVAS)

The WaterCar EV is an electric vehicle subject to FMVSS 141 (Minimum Sound Requirements for Hybrid and Electric Vehicles). The vehicle is equipped with an AVAS to provide an audible alert to pedestrians and other road users at low speeds.

✓ CONFIRMED

The Acoustic Vehicle Alerting System (AVAS) emits an audible pedestrian alert when the vehicle is traveling below 20 mph in both forward and reverse. The system is designed to meet FMVSS 141 requirements for minimum sound levels at pedestrian-relevant speeds. The AVAS activates automatically and requires no operator action.

4.4 FCC / Radio Compliance

The WaterCar EV touchscreen display and infotainment system contain radio components. This device complies with Part 15 of the FCC Rules. Operation is subject to the following two conditions: (1) This device may not cause harmful interference, and (2) this device must accept any interference received. Changes or modifications not expressly approved by the party responsible for compliance could void the user's authority to operate the equipment.

4.5 Vehicle Description & Controls

The WaterCar EV is a battery-powered Low Speed Vehicle (LSV). On land, propulsion is provided by a 48V electric motor. The vehicle seats up to 4 persons and is limited to a maximum on-road speed of 25 MPH per federal LSV regulations.

[IMAGE PLACEHOLDER]

Vehicle overview diagram — labeled side view and top-down plan showing key component locations: 48V battery, 12V battery, hydraulic pump, helm controls, drain plug, VIN plate, D-ring tie-down points, zerk fitting locations

Console Controls

Ref	Control	Description
B	On / Off Batt Disconnect	Large red Batt Turn Switch — immediately stops electric motor
E	Curtis Display	Shows battery state, motor status, and fault codes
F	Motor Key Switch	Powers on/off the 48V electric drive system (ProDrive™)
G	Touchscreen	Speed display + Apple CarPlay infotainment
H	Push Button Panel	7 buttons: display, headlights, nav lights, anchor light, auxiliary x2, horn
I	Fwd/Neutral/Rev Switch	Controls electric motor direction
J	Turn Signal / Hazard	Left/right turn signals; both simultaneously = hazard lights

[IMAGE PLACEHOLDER]

Console control diagram — labeled photograph or engineering illustration of helm console identifying controls B, E, F, G, H, I, J. PORT (marine) and STARBOARD (road) control zones clearly labeled.

Dashboard Indicator Lamps

Indicator	Condition	Required Action
Battery — Green (100–50%)	Normal operating range	No action required
Battery — White (49–20%)	Moderate discharge	Plan for recharge; monitor closely
Battery — Red (19–0%)	Low battery	Return to charging location immediately
Fault Code	Controller detected fault	Stop safely; note code; contact WaterCar
Park Brake	Park brake engaged	Disengage before driving
Seat Belt	Seat belt not fastened	Fasten seat belt before operating
Direction (F/N/R)	Current drive mode	Confirm direction before accelerating

✓ CONFIRMED

The Curtis® controller enters sleep mode after approximately 30 minutes of inactivity when the key is left in the ON position (2026 and later models). Pre-2026 models may not include an automatic timeout. To exit sleep mode, cycle the key switch OFF and back to ON. At critically low state of charge, the controller will progressively limit vehicle speed. Refer to the Eco Battery BMS codes (Section 3.4) for low-SOC behavior indicators.

Push Button Panel

Button	Function
Button 1	Display Power
Button 2	Headlights
Button 3	Navigation Lights (Port/Starboard/Stern)
Button 4	Anchor Light (all-round white)
Button 5	Front Bilge Pump

Button 6	Rear Bilge Pump
Button 7	Horn
Button 8	Rear View Camera

Dash Layout — PORT vs. STARBOARD

- PORT (left) side — Marine controls: Mercury ignition key, throttle/shift lever, Mercury display screen, hydraulic wheel switches (FRONT and REAR rockers), navigation lights, bilge pump, horn.
- STARBOARD (right) side — Road/Land controls: FNR toggle, turn signal buttons, electric motor key switch, 48V state of charge gauge.
- CENTER — Touchscreen infotainment display (Apple CarPlay), speedometer.

Reverse Camera

The WaterCar EV is equipped with a reverse camera. The camera activates automatically when the Drive Forward/Reverse Switch is placed in the Reverse position and the display is powered on.

⚠ WARNING

The reverse camera is an aid only. Always visually check your surroundings and physically inspect the area behind the vehicle before reversing. The camera has blind spots and does not replace a physical inspection.

Hub Bearing Health Check

- Step 1 — Visual & Touch: After an extended drive, touch each rear hub. Compare both sides — a failing bearing may feel noticeably hotter. Check for grease leaks near the seal.
- Step 2 — Spin & Listen: Jack up one rear wheel. Spin by hand. It should feel smooth and silent. Grinding or roughness means replacement is required.
- Step 3 — Rock Test: Grab the tire at 12 and 6 o'clock and rock it. Any looseness indicates bearing wear.
- Step 4 — Road Noise Test: Drive at 25 MPH with windows down. Listen for rumbling or humming that changes with speed or turns.

⚠ WARNING

Replace bearing immediately if: hub is hotter than the other side — grinding, whirring, or knocking sounds — visible grease leaking — any wheel play during the rock test.

4.6 Pre-Ride Inspection Checklist

Perform before each use. Do not operate if any item does not pass.

Item	Check	Ref
Tire pressure	Check and adjust to 35 PSI	4.13
Tire condition	Inspect for cuts, punctures, cracks, bulges	4.13
Wheel nuts	Confirm tight; no looseness or wobble	4.13
Brake pedal	Firm travel; no spongy feel	4.9

Brake fluid	Check reservoir level; inspect for leaks	4.14
Brake lights	Confirm illuminate when pedal is pressed	—
Park brake	Confirm engages and releases smoothly	4.9
Seat belts	Inspect for damage; confirm latch operates	Sec. 2
Headlights	Confirm operation	4.15
Turn signals	Confirm all signal lights operate correctly	—
Horn	Confirm operation	—
Steering	Smooth operation; no excessive freeplay	4.15
Accelerator pedal	Proper operation; returns to rest position	—
48V battery	Check state of charge; power-on indicator lit	Sec. 3
12V battery	Check charge; terminals clean and tight	Sec. 3
Battery compartments	Inspect for moisture, corrosion, damage; lids secured	Sec. 3
Mirrors	Adjust for clear side and rear view	—
Surroundings • Hydraulic wheels — confirm all four wheels are fully deployed and locked in the down position. No rubbing or contact during full steering lock left and right.	Clear path; no obstacles; route confirmed	—
Door latch	Confirm door latch engages securely; door fully closed before operation	—
Hydraulic fluid	Check fluid levels in both hydraulic pumps; verify within recommended range. Inspect for leaks at fittings and hose connections.	—
Outboard kill switch [Marine Package]	Confirm safety lanyard bungee cord is fitted and operational; switch in RUN position	Sec. 5

4.7 Power-On Sequence

20. Press and hold the 48V battery power button until the green LED illuminates (approximately 1 second), then release.
21. Turn BOTH large red battery master switches (beside the driver's seat panel) to the ON position.
22. Confirm the 48V state of charge gauge illuminates.
23. Confirm the 12V gauge reads approximately 13V.
24. Turn the Electric Motor Key Switch to the ON position — you will hear a relay click.

NOTICE

If the vehicle arrives by transport carrier with low or dead batteries, this is normal. Both batteries fully recover with a standard charge. Contact WaterCar if a battery does not recover after a full charge cycle. WaterCar: (714) 253-7186.

4.8 Driving Procedure

25. Confirm the pre-ride inspection is complete and all items pass.
26. Sit in the driver's seat. Fasten your seat belt. Ensure all passengers are seated with seat belts secured.
27. Activate the 48V battery by pressing the power button — confirm green LED illuminates.
28. Engage both red battery master switches to the ON position.
29. Turn the Electric Motor Key Switch to ON.
30. Apply the brake pedal.
31. Release the park brake. Confirm the park brake indicator is no longer illuminated.
32. Move the Drive Forward/Reverse Switch to the Forward (F) position.
33. Check your surroundings and confirm your path of travel is clear.
34. Keeping both hands on the steering wheel, gradually depress the accelerator pedal to begin driving.
35. Use turn signals before every turn or lane change.
36. To stop: release the accelerator and apply the brake to a complete stop.
37. Set the park brake. Turn the key off. Remove the key if leaving the vehicle.
38. Recharge the batteries after each use.

⚠ WARNING

Never turn the Key Switch to the OFF position while the vehicle is in motion. Doing so can lead to loss of speed control, potentially resulting in serious injury or death.

4.9 Throttle Fault — Curtis Controller

The WaterCar EV uses a Curtis electronic motor controller with built-in safety logic. A throttle fault may occur if the accelerator pedal is pressed with very light, short, or hesitant inputs.

- Symptom: vehicle does not respond to accelerator pedal, may display a fault code.
- Resolution: fully release the accelerator pedal completely, then re-apply with a smooth, deliberate motion.
- Directional fault: can also occur if Forward and Reverse are toggled too quickly — clear by cycling key OFF, wait 3 seconds, then ON.

⚠ NOTICE

Throttle faults are normal behavior of the self-protecting electronic controller — not a vehicle malfunction. Always apply the accelerator with smooth, intentional pressure.

4.10 Driving in Reverse

Always come to a complete stop before reversing direction. Move the Drive Forward/Reverse Switch to the Reverse (R) position. The reverse camera activates automatically.

39. Physically check behind the vehicle before reversing. Do not rely solely on the camera.
40. Avoid backing downhill. Back slowly. Apply brakes lightly for stopping.
41. Avoid turning at sharp angles in reverse. Never accelerate suddenly.

⚠ WARNING

Always physically confirm no obstacles or people are behind the vehicle before reversing.

4.11 Driving on Slippery Surfaces

- Do not operate on excessively slippery surfaces.
- Slow down before driving onto a slippery surface.
- Avoid quick, sharp turns, which can cause skids.
- Correct a skid by turning the steering wheel in the direction of the skid. Never apply the brakes during a skid.
- Regenerative braking increases the chances of traction loss on slippery surfaces. Reduce speed and allow extra stopping distance.

4.12 Parking & Braking

Parking on a Level Surface

42. Apply the brakes and stop the vehicle on a level surface.
43. Move the direction switch to neutral. Set the park brake.
44. Turn the key off and remove it.

Parking on an Incline

45. Apply the brakes. Set the park brake. Place direction selector in neutral. Turn key off.
46. Block the wheels on the downhill side of the vehicle.
47. If parking facing downhill near a curb: turn steering wheel toward curb. If facing uphill: turn wheel away from curb.

⚠ DANGER

Do not use the vehicle on slopes greater than 1:5 (20%). Do not drive the vehicle across slopes. A rolling vehicle can cause serious injury or death.

Manual disc brakes provide reliable stopping power. Always apply steady, even pressure.

⚠ NOTICE

Be sure the park brake is fully disengaged before driving. Driving with the park brake engaged causes brake overheating and can damage the mechanical suspension components.

After releasing the parking brake, listen for any rubbing or dragging sounds from the rear wheels during the first few seconds of driving. If rubbing is present, stop and confirm the parking brake is fully disengaged. Driving with the brake partially engaged causes overheating and premature wear.

The parking brake operates independently of the main braking system through a cable mechanism that engages the rear brakes. It is designed to keep the vehicle stationary when parked and to serve as an emergency braking system if the primary brakes fail.

Depending on your vehicle model and year your parking brake may be manual pull cable or automatic with additional hydraulic lock at rear wheels. To engage manual system: pull the lever firmly until you feel resistance and the vehicle is securely held. For the automatic, the Curtis® controller applies and disengages automatically putting the vehicle in park mode. It

is also recommended to apply the rear wheel hydraulic lock with the automatic Curtis differential lock.

Always apply the parking brake when parked, even on flat surfaces. When ready to drive, push the lever back down and confirm it is fully disengaged before moving.

Ensure the brake engages and releases smoothly. If you notice difficulty engaging, lack of holding power, or unusual sounds, have it inspected and repaired by a qualified technician before further operation.

4.13 Transporting by trailer & Towing

Transporting the WaterCar EV for Shipping ON TRAILER.

48. Turn the key off. Turn off both battery systems.
49. Secure the vehicle using tie-down straps of sufficient WLL attached to the designated D-ring tie-down points.
50. Use the tow bar hydraulic support angle irons (included in care package) while towing.

⚠ WARNING

Do not add additional weight to the vehicle during transport. The vehicle is designed to be transported empty.

Towing the WaterCar EV – with TowLink™ — NO TRAILER NEEDED

- Use the Rear Wheel Hydraulic Switch to adjust the front height to align with your towing vehicle's hitch ball.
- Locate the hitch pin inside the front bow. Pull out the hitch pin, align and insert the trailer hitch into the mount, reinsert the hitch pin to lock.
- Once vehicle is attached to vehicle – raise the front wheels – VERY IMPORTANT – DO NOT TOW WITH FRONT WHEELS IN DOWN POSITION.
- The WaterCar EV tows on its rear wheels.
- Confirm brake lights, turn signals, and safety chains are properly connected. Attach safety tow cables to the D-ring.

Out-of-Water Lifting

When lifting the WaterCar EV out of the water using a crane, hoist, or marine travel lift, observe the following:

- Use wide, flat, belted slings to minimize stress on the hull. Do not use narrow straps or cables that concentrate load on a small area.
- Position slings carefully. Do not place slings where they will contact underwater fittings, drain plugs, or the outboard engine.
- If using a lifting hook, attach to the designated bow eye and transom tow eyes. Use a spreader bar on the transom eyes. Use chafe protection on the top of the transom.
- Remove all drain plugs after lifting. Position the vessel with the bow slightly higher than the stern to allow any accumulated water to drain.
- If using a professional lifting service, verify credentials and proof of insurance.
- Do not use the bow eye or stern eyes for long-term suspension. Extended lifting with these points can stress the hull and surrounding structure.

⚠ CAUTION Long-term lifting or suspension by the bow and stern eyes can cause stress on the hull structure and is not recommended. For storage, support the vessel on a bunk-style trailer or cradle that distributes weight evenly along the keel.

4.14 LSV Specifications

⚠ NOTICE

Subject to change without notice. Verify against VIN plate for your specific unit.

Specification	Value
Classification	Low Speed Vehicle — 49 CFR Part 571.500 (FMVSS 500)
Top Speed (LSV Limited)	25 MPH / 40 KM/H
Overall Length	19.5 FT / 6 M
Width	6.5 FT / 1.98 M
Height Without Top	5.66 FT / 1.52 M
Height With Top	6.58 FT / 2.0 M
Wheels	14 IN / Aluminum
Tires	27 x 8.50 R14/6
Turning Circle Radius	24 FT / 7.32 M
GVWR	2,995 LBS / 1,356 KG
Curb Weight — LSV (est.)	2,000 lbs (907 kg)
Seating	2 or 4 Persons
Battery — Primary Drive	48V / 160 AH / Eco Battery® Gen3 LiFePO4
Battery — Auxiliary	12.8V / 120 AH / Epoch DP12120H LiFePO4
Range on Land	18+ Miles / 32 KM
Hydraulic Pump	Mercury/Quicksilver 865380A25

4.15 Wiring Diagrams, Hydraulic Schematics & Fitting Reference

All wiring diagrams, hydraulic schematics, and hydraulic fitting reference information have been consolidated in Appendix B — Schematics & Technical Reference at the end of this manual.

4.16 Land Maintenance Schedule

Interval	Item	Action
Before each use	Pre-ride inspection	Complete checklist (Section 4.6)
Before each use	Tire pressure	Check and adjust to 35 PSI
Before each use	Battery charge	Verify 48V and 12V charge levels
Before each use	Seat belts	Inspect for damage; confirm latch operates

Monthly	Battery cables & terminals	Check for corrosion, frayed wires, tight connections
Monthly	Brake fluid level	Inspect reservoir; check for leaks
Monthly	Steering freeplay	Turn wheel lightly; confirm freeplay within spec
Monthly	Lights & signals	Confirm headlights, brake lights, turn signals, horn
Monthly	Wheel nuts	Inspect for tightness
Monthly	Zerk fittings	Grease all hydraulic pivot points — use included grease gun
Every 5,000 mi	Tire rotation	Rotate all four tires
After 1st 100 mi	Wheel nut torque	Re-torque after first 100 miles and after any wheel removal
Twice yearly	Battery inspection	Full removal; inspect for corrosion and case damage
Twice yearly	Hydraulic fluid	Check levels in both pumps; top off if needed
Every 2 years	Brake fluid	Replace with specified fluid; replace sooner if contaminated
Annually	Fire extinguisher	Check expiration date and condition
As needed	Tread depth	Replace tires at or below 1/8 in (3 mm)
As needed	Brake pads/discs	Inspect for wear; replace at minimum thickness

4.17 Tires & Wheels

Specification	Value
Tire Size	27 x 8.50 R14/6
Wheel Size	14 in / Aluminum
Wheel Nut Torque	85 foot lbs
Tread Depth Minimum Recommended Tire Pressure: 35 PSI	1/8 in (3 mm)

⚠ WARNING

Driving with worn, improperly inflated, non-standard, or incorrectly installed tires can impair vehicle handling and lead to accidents. Always use the original equipment tire size and type.

Wheel Removal

51. Position vehicle on dry, firm, level surface. Set park brake and turn off ignition.
52. Block front and rear of the tire diagonally opposite the jacking position.
53. Use only a small floor jack or low-profile scissor jack. Lift from the main frame rail.

54. Remove wheel nuts and take off the wheel.

Wheel Installation

55. Set parking brake. Place wheel in position — valve stem facing outward, rotation arrows pointing forward.

56. Attach wheel nuts and finger-tighten. Lower vehicle to ground.

57. Torque wheel nuts to specification in a crisscross pattern. Re-torque after first 100 miles.

⚠ WARNING

A falling vehicle can cause serious injury or death. Never place any part of your body under a raised vehicle. Use automotive jack stands.

Axle and Differential Service Specifications

The following specifications are provided for qualified service technicians. Do not attempt axle or differential service unless properly trained and equipped.

- Axle nut torque: 200 ft-lbs with blue Loctite. Mark and peen after torquing.
- Rear hub torque: per WaterCar specification with safety wire installed.
- Differential oil capacity: limited slip differential — 22 oz gear oil + 2 oz limited slip additive. Non-limited-slip differential — 24 oz gear oil total. Record date and technician name at each service.
- Confirm whether your vehicle has a limited slip differential — this determines the correct oil fill procedure. Contact WaterCar if unsure.

4.18 Brakes

Manual disc brakes provide reliable stopping power through a mechanical linkage that applies pressure to brake pads, which clamp onto the brake discs (rotors). This frictional force slows and stops the vehicle. Manual disc brakes are known for simplicity, reliability, and ease of maintenance.

When operating, always apply steady and even pressure to the brake pedal for smooth, controlled braking. Avoid sudden or harsh braking, as this causes premature wear of brake pads and discs. Familiarize yourself with the feel and responsiveness of your brakes. Braking performance is affected by vehicle load, road conditions, and weather — always adjust your braking accordingly.

Brake pads should be replaced when they show signs of excessive wear or when braking efficiency is noticeably reduced. Brake discs should be checked for scoring or warping, which can affect performance. Regular maintenance and timely replacement of these components maintains braking safety.

Brake Inspection — check before each use:

58. Check the brake system for fluid leaks.
59. Check the brake pedal for excessive travel or a spongy feel.
60. Check the friction pads for wear, damage, and looseness.
61. Inspect the brake disc surface for excessive wear or scoring.

Inspect brake fluid level before each operation. Level should be between MAX and MIN lines on reservoir. Replace brake fluid every two years and any time the fluid becomes contaminated.

4.19 Steering & Headlight Inspection

The WaterCar EV uses a Unisteer® rack-and-pinion steering unit with electric power steering assist. The electric power steering system is maintenance-free and requires no hydraulic fluid checks or adjustments. Steering should operate smoothly without binding or excessive play.

62. Position vehicle on level surface with wheels pointing straight ahead.
63. Lightly turn the steering wheel left and right to check freeplay at the outer rim.
64. If there is excessive freeplay, strange noises, or rough feel, do not operate until inspected by a qualified technician.

Keep headlight and taillight lenses clean. Replace LED lamps promptly. To verify headlight aim: place the vehicle 25 feet from a wall on a level surface, turn on the headlights, and confirm the beam is aimed below the height of the headlight center.

4.20 State Regulatory Reference — LSV

⚠ WARNING

This table may not reflect the most current state laws. The owner is responsible for verifying current registration, titling, insurance, and operator licensing requirements in each state of operation.

State	LSV Road Operation	Notes
California	Permitted on roads 35 mph or less	LSV sticker required; verify DMV requirements
Florida	Permitted on roads 35 mph or less	Boater safety education may be required for vessel registration
Texas	Permitted on roads 35 mph or less	Verify county-specific regulations
Arizona	Permitted on designated roads	Contact AZ MVD for current requirements
Nevada	Permitted on roads 35 mph or less	Contact NV DMV for current requirements
New York	Shall not operate on roads with speed limit greater than 35 mph	Contact NY DMV
Maryland / Illinois	Shall not operate on roads with speed limit greater than 30 mph	Contact state DMV
All Other States	Operator must verify local laws	Contact WaterCar or state DMV

For current federal LSV regulations: www.nhtsa.gov

SECTION 5**Marine Water Operation**

Standalone — applies to Marine Package configuration only

5. Marine Water Operation

This section covers all aspects of operating the WaterCar EV as a recreational vessel on water. This section is self-contained — Marine Package owners will find everything needed for safe water operation here. Read this section completely before any water operation.

▲ NOTICE

This section provides operational guidance specific to the WaterCar EV vessel configuration. It does not replace a formal boating safety course. WaterCar strongly recommends that every operator complete a USCG-approved boating safety course before operating this vessel for the first time.

5.1 Marine Regulatory Classification

The WaterCar EV in its Marine Package configuration is a federally regulated recreational vessel subject to U.S. Coast Guard authority under 46 USC §4307/4311 and applicable manufacturing standards under 33 CFR Parts 181 and 183.

Regulation	Subject
33 CFR Part 181	Manufacturer requirements for recreational vessels — HIN, capacity labeling, certification
33 CFR Part 183	Equipment standards — flotation, fuel systems, electrical, ventilation
46 USC §4307/4311	USCG enforcement authority; penalties for violation
33 CFR Part 175	Equipment requirements — PFDs, fire extinguishers, signals
33 CFR Parts 84–90	Navigation rules (CoRegs) applicable to U.S. waters
State Law	Vessel registration, titling, operator licensing, and equipment requirements vary by state

Certification Design Category

Recreational vessels are assigned design categories based on wind and wave conditions for which they are designed. These categories are used for CE (international) certification and inform operators of the vessel's intended operating envelope:

Category A (Ocean):

Designed for winds exceeding Beaufort Force 8 and significant wave heights above 4 meters, excluding abnormal conditions such as hurricanes or rogue waves.

Category B (Offshore):

Designed for winds up to and including Beaufort Force 8 and significant wave heights up to and including 4 meters.

Category C (Inshore):

Designed for winds up to and including Beaufort Force 6 and significant wave heights up to and including 2 meters.

Category D (Sheltered Waters):

Designed for winds up to and including Beaufort Force 4 and significant wave heights up to and including 0.3 meters, with occasional waves of 0.5 meters maximum height.

⚠ NOTICE The WaterCar EV's design category is documented on the capacity plate (Section 5.5). The operator is responsible for not exceeding the conditions specified by the assigned design category. Reduce passenger count and cargo in adverse weather regardless of the rated capacity.

5.2 Hull Identification Number (HIN)

A permanent HIN is affixed to your vessel at manufacture in accordance with 33 CFR Part 181, Subpart C. The HIN is a 12-character identifier used for vessel registration and Coast Guard identification.

HIN Location: The primary HIN is located on the transom of the vessel, on the starboard side, within two inches of the top of the transom. A duplicate HIN is located in a concealed location on the interior of the hull.

⚠ NOTICE

The HIN must never be removed, altered, or obscured. It is a federal offense to alter or remove a HIN under 46 USC §4311. Record your HIN on the Delivery Acknowledgment Form.

5.3 NMMA Certification

WaterCar Inc. is an NMMA-certified manufacturer. The vessel is manufactured in accordance with applicable National Marine Manufacturers Association (NMMA) standards, verifying compliance with applicable ABYC, NFPA, and USCG standards for recreational vessel manufacturing.

5.4 USCG Vessel Registration

The vessel must be registered with the appropriate state boating agency prior to water operation in most jurisdictions. The owner is responsible for determining applicable registration requirements in each state of intended operation.

⚠ NOTICE

Federal law does not require vessel registration for all recreational vessels, but most states do. Always verify current state requirements before operating on state waters.

5.5 Capacity Plate

A capacity plate is affixed to the vessel in a location visible to the operator at the helm. The capacity plate displays the maximum persons capacity, maximum weight capacity, and maximum horsepower rating. Never exceed the values shown.

**⚠ WARNING**

NEVER EXCEED THE CAPACITY PLATE VALUES. Overloading or exceeding the rated horsepower creates a risk of swamping, capsizing, or loss of control.

5.6 Marine Safety**⚠ DANGER**

CARBON MONOXIDE (CO) POISONING CAN KILL YOU. Carbon monoxide is a colorless, odorless gas produced by the outboard engine. CO can accumulate in enclosed or semi-enclosed spaces including the cockpit area, especially at idle or low speed with following wind conditions. **SYMPTOMS:** Headache, dizziness, nausea, confusion, loss of consciousness. If symptoms occur: move immediately to fresh air, shut down the engine, and seek medical attention. **NEVER** run the engine in an enclosed space. **NEVER** allow passengers to ride in downwind positions at the stern while underway at idle.

⚠ DANGER

ROTATING PROPELLER CAUSES SEVERE INJURY OR DEATH. Keep all persons clear of the propeller at all times. **SHUT DOWN THE OUTBOARD ENGINE** completely before any person enters the water, approaches the stern, or handles lines near the propeller. Confirm the engine is off and the propeller has stopped rotating before boarding or exiting the vessel.

Risk of Loss of Stability

Stability is a critical aspect of boat safety. Stability refers to the vessel's ability to return to an upright position after being tilted by waves, wind, or other forces. Loss of stability can lead to capsizing, swamping, or sinking. It is important to recognize and mitigate the factors that can compromise stability to ensure safe operation. The distribution of weight is one of the primary concerns. Uneven weight distribution — whether from passengers, gear, or fuel — can cause the vessel to list to one side, increasing the risk of capsizing. Balance the load evenly and avoid sudden shifts in weight. Overloading the vessel beyond the rated capacity lowers the freeboard (the distance from the waterline to the deck), making the vessel more susceptible to taking on water in rough conditions.

Environmental conditions also play a significant role. High winds, large waves, and strong currents can challenge stability. Operators must adjust speed and heading to minimize the impact of these forces. Avoid navigating in adverse weather whenever possible. Stay informed about weather forecasts and water conditions before departure.

The vessel's condition is fundamental to its stability. Conduct regular maintenance checks to ensure all components — including the hull, bilge pumps, and drainage systems — are in good working order. Any modifications or repairs must be performed according to WaterCar specifications. Operators should familiarize themselves with the vessel's design limitations and performance characteristics.

⚠ WARNING

Maintaining stability is paramount for safe operation. Pay attention to weight distribution, environmental conditions, and vessel maintenance. Never exceed the capacity plate values. Sudden shifts in passenger or cargo weight while underway can cause loss of stability without warning.

Risk of Flooding

The WaterCar EV is designed for water operation, but uncontrolled water ingress can compromise stability, damage electrical systems, and create a life-threatening emergency. The following openings and access points must be properly secured before water entry and monitored during water operation:

- Door — must be fully closed and latched before water entry. An unlatched door can allow rapid flooding.
- Dash hatch — must be securely shut and inspected for proper seal. Water entering through the dash hatch can reach electrical components.
- Battery compartment hatch — must remain closed at all times during water operation. Inspect for water in the battery compartment before each use.
- Drain plug — must be installed and secure before water entry. A missing or loose drain plug will cause immediate flooding.
- Cockpit drains — ensure drains are not blocked and the cockpit can drain freely. Debris in the cockpit drains can cause water to accumulate.

⚠ WARNING

In rough weather or when operating in waves, keep all hatches and compartments closed to minimize water ingress. Check the function of bilge pumps regularly, clear debris from their inlets, and test operation before each water use. If the bilge pump runs continuously or water level rises during operation, return to shore immediately.

5.7 USCG Required Equipment

Equipment	Requirement	Note
Personal Flotation Devices	One USCG-approved Type I, II, III, or V wearable PFD for each person onboard. At least one throwable Type IV device.	Stowed and accessible — not buried in storage
Fire Extinguisher	At least one USCG-approved Type B-I fire extinguisher.	Fully charged, accessible, inspected annually
Sound-Producing Device	Horn, whistle, or bell audible at least 0.5 nautical miles.	Onboard and functional
Navigation Lights	Red/green bow lights, white stern light — required from sunset to sunrise and in restricted visibility.	Test before each night operation
Visual Distress Signals	Required on coastal waters, Great Lakes, and territorial seas.	Check expiration dates

Kill Switch Lanyard

Operator must attach kill switch lanyard to person, PFD, or wrist when underway.

Attached before engine start

⚠ WARNING

THE OPERATOR MUST ATTACH THE KILL SWITCH LANYARD TO THEIR PERSON, PFD, OR WRIST AT ALL TIMES WHILE THE ENGINE IS RUNNING. Failure to use the kill switch lanyard as required may result in serious injury or death.

5.8 Navigation Lights

Light	Arc of Visibility
Red (port bow)	Visible from dead ahead to 112.5° to port
Green (starboard bow)	Visible from dead ahead to 112.5° to starboard
White (stern)	Visible from astern through 135° arc
White (anchor light)	<p>All-round light required when at anchor in a navigable waterway</p> <p>Navigational lights are essential for safe boating during low visibility conditions — at night, during fog, or in heavy rain. They help other boaters identify your vessel's size, direction, and activity, reducing the risk of collisions.</p> <p>The bow is equipped with a bi-colored light: green on the starboard (right) side and red on the port (left) side. These lights indicate the vessel's direction to other vessels. When another boat sees the green light, it knows it is seeing the starboard side. The red light indicates the port side.</p> <p>At the stern, an all-round white light serves as both a stern light and an anchor light. This light is visible from all directions (360 degrees), ensuring visibility in crowded or poorly lit areas.</p> <p>Using Lights While Anchored</p> <p>When anchored, only the all-round white (anchor) light should be illuminated. This signals to other boaters that your vessel is stationary. Activate the anchor light using Button 4 on the push button panel. Check that the light is functioning before nightfall.</p>

⚠ CAUTION

Before setting out, ensure all navigation lights are functioning properly. Carry spare bulbs for each light. Always replace bulbs with ones of the same wattage. Proper use of navigational lights is both a safety measure and a legal requirement.

Steering Position Visibility

The steering position has been located to provide the operator with an optimal field of view. The height and angle of the steering console accommodate operators of various heights.

Regular maintenance and inspection of the windshield is essential. Clean the windshield regularly to remove dirt, salt, or water spots. All navigational instruments are arranged to be readable at a glance without diverting attention from the water.

- Keep the area around the steering position clear of loose items and clutter that could obstruct visibility.
- In adverse weather (fog, rain, heavy seas), exercise extra caution and reduce speed.
- Ensure passengers understand the importance of keeping the helm area clear during operation.

5.9 Float Plan

Before every water operation, file a float plan with a responsible person ashore. Include: vessel description and registration number, HIN, names of all persons onboard, intended destination and route, expected return time, and emergency contact information.

⚠ NOTICE

USCG Boating Safety: 1-800-368-5647 | www.uscgboating.org

5.10 Charging Prohibition — In Water

⚠ DANGER

NEVER CONNECT SHORE POWER OR CHARGE EITHER BATTERY WHILE THE VESSEL IS IN THE WATER. Charging in water creates risk of electric shock drowning (ESD) — an invisible current in the water around the vessel that can incapacitate or kill swimmers. ALWAYS retrieve the vessel from the water and charge on dry land using a GFCI-protected outlet only.

5.11 Fueling Safety

⚠ WARNING

GASOLINE IS EXTREMELY FLAMMABLE AND EXPLOSIVE. Before fueling: stop the engine, extinguish all open flames and smoking materials, turn off all electrical switches. Do not overfill. Wipe up all spills immediately. After fueling: ventilate the bilge and engine compartment for at least 5 minutes before starting the engine. Sniff the bilge before starting — if you smell fuel, do not start the engine.

Static Electricity & the Fuel System

Static electricity can ignite gasoline vapors that have not been ventilated from enclosed spaces. The vessel's bonding system is designed to protect against static discharge, but only functions when the vessel is in contact with the water or a land-based grounding system. The following precautions must be observed during all fueling operations:

- Never fuel the vessel while suspended on a sling, lift, or in any configuration where the hull is not grounded.
- Never use homemade or unapproved containers to fill fuel tanks.
- Keep the fuel nozzle in contact with the fuel tank opening or fill plate throughout the fueling process to prevent static discharge.
- Shut down all engines, motors, and electrical equipment before fueling. Extinguish all ignition sources.
- Allow enclosed spaces where gasoline vapors could collect to ventilate before starting the engine.
- Wipe any spillage completely and dispose of rags on shore.

⚠ DANGER Static electricity can ignite gasoline vapors, causing serious injury, death, and destruction of property. Always maintain metallic contact between the fuel nozzle and the tank opening during fueling. Never fuel in ungrounded conditions.

5.12 Operator Responsibilities — Water

Requirement	Details
FLOAT PLAN	File a float plan with a responsible person ashore before every water operation.
EQUIPMENT	Verify all USCG-required equipment is onboard and serviceable before departing.
KILL LANYARD	Attach kill switch lanyard to person before starting engine. Required at all times underway.
PFDs	Ensure all persons have access to an appropriately sized, USCG-approved PFD.
WEATHER	Check weather forecast before departure. Do not operate in conditions that exceed skill level or vessel capability.
SOBER	Never operate under the influence of alcohol or drugs. BAC limits apply to vessel operation.
RULES OF THE ROAD	Know and follow the Navigation Rules (ColRegs) applicable to your operating area.
STATE LAW	Verify applicable state boating laws for each state of operation before departure.
INSPECTION	Inspect the vessel before every water operation.

Swimming, Diving & Water Activities

When the WaterCar EV is used in navigable waters, the operator must be aware of swimmers, divers, and persons engaged in water sports in the vicinity. Federal and state laws impose strict obligations on vessel operators to protect persons in the water.

Swimming from the Vessel

- Do not swim from or near the vessel while the outboard engine is running. Shut off the engine and remove the key before anyone enters the water.
- Turn off the engine in gear (to prevent propeller windmilling) before approaching or picking up any person in the water.
- Never allow anyone to board or exit the vessel from the water while the engine is running.
- Many jurisdictions prohibit swimming from a vessel except in designated areas. Know and comply with local restrictions.

Diver Recognition

- A red flag with a diagonal white stripe (Sport Diver's Flag) marks a diver in the water. Keep at least 100 feet (30 meters) away.
- A blue-and-white pennant (Code Alpha Flag) designates a vessel engaged in dive operations.

Water Skiing & Towed Water Sports

If towing skiers, tubers, or other water sports participants using the transom tow point:

- Always have at least two persons in the vessel: one at the controls and one observer watching the person being towed at all times.
- All persons being towed must wear a USCG-approved personal flotation device (PFD).
- Tow only during daylight hours when visibility is good.

- Never drive directly behind a person being towed. At 25 mph, it takes only 5 seconds to overtake a fallen skier who was 200 feet ahead.
- Use the transom tow point only for towing water skiers and wakeboarders. Do not use for parasailing, towing other vessels, or any use that exceeds the rated capacity of the tow point.
- Keep a downed skier in sight at all times. Turn off the engine in gear before approaching any person in the water.
- If a skier releases the tow rope, it may backlash into the cockpit. The observer must be aware of this hazard.

⚠ WARNING USE THE TRANSOM TOW POINT ONLY FOR TOWING WATER SKIERS AND WAKEBOARDERS. Using the tow point to tow boats, parasails, or other loads exceeding its rated capacity may result in structural failure, serious injury, or death.

Water Skiing Hand Signals

The skier communicates with the vessel operator through standardized hand signals: Faster (thumb up), Slower (thumb down), Speed OK (circle with thumb and index finger), Turn (arm raised, circle with finger), Stop (palm forward), OK After Fall (hands clasped overhead), Skier in Water (one ski vertical), Cut Motor (finger across throat), Back to Dock (pat top of head). Learn and use these signals before towing.

Homeland Security Restrictions

Recreational vessel operators must observe federal homeland security restrictions. Do not approach within 100 yards of any U.S. Naval vessel, and slow to minimum speed within 500 yards. If safe passage requires passing within 100 yards, contact the naval vessel or Coast Guard escort on VHF-FM Channel 16. Observe and avoid all marked security zones, especially near military, cruise line, or petroleum facilities. Do not stop or anchor beneath bridges or in navigable channels. Report suspicious activity on America’s Waterway Watch hotline: 877-24WATCH (877-249-2824).

⚠ DANGER DO NOT approach within 100 yards of any U.S. Naval vessel without first contacting the vessel on VHF-FM Channel 16. Failure to comply will result in a quick and severe response.

5.13 Water Controls & Helm

[IMAGE PLACEHOLDER]

Helm control diagram — labeled photograph or engineering illustration of the WaterCar EV helm showing: throttle/shift lever, trim switch, kill switch, instrument panel, push button panel, hydraulic wheel switches (front/rear rockers), PORT marine controls vs. STARBOARD road controls

Outboard Engine Controls

Control	Description
Throttle/Shift Lever	Single lever controls both gear (Forward/Neutral/Reverse) and throttle. Forward = push, Reverse = pull. Neutral = center detent.
Engine Trim Switch	Adjusts outboard angle. Trim up = raise, Trim down = lower. Starting trim position: approximately 45 on Mercury display screen. Once on plane at 5,500–6,000 RPM, back off throttle to cruise speed and adjust trim to approximately 60–65 for optimal ride angle. Higher trim numbers raise the bow for a drier ride in choppy conditions. Trim settings are dependent on water conditions, passenger/cargo weight, and operator preference.
Engine Tilt (Full)	Raises outboard fully for shallow water, launching, and retrieval. Do not run engine at full tilt angle.
Kill Switch	Stops engine immediately. Always attach kill switch lanyard to person before starting.
Engine Start / Stop	Located at helm console. Refer to Mercury owner's manual for starting procedure.

Bilge Pump

The vessel is equipped with an automatic bilge pump that activates when water accumulates in the bilge to a preset level. A manual override switch is located at the helm console. Check bilge pump operation as part of the pre-launch checklist.

⚠ WARNING

If the bilge pump runs continuously or frequently, the vessel may be taking on water. Stop operation, investigate the source, and return to shore immediately.

Electric Drive System (ProDrive™) — Water Lockout

⚠ WARNING

DO NOT ENGAGE THE ELECTRIC DRIVE MOTOR WHILE THE VESSEL IS IN THE WATER. The electric motor is designed for on-road operation only. Engaging the electric drive on water may result in drivetrain damage, electrical hazards, or loss of control.

VesselView 903 Display (DualCommand™)

The WaterCar EV is equipped with a Mercury® VesselView 903 multi-function display (DualCommand™) at the helm. The VesselView 903 provides real-time engine data from the SmartCraft network, including RPM, engine temperature, oil pressure, battery voltage, fuel flow, and diagnostic fault codes. The display also supports GPS navigation, mapping, and maintenance reminders.

Refer to the Mercury VesselView 903 owner's manual included in your Owner's Manual Packet for complete operating instructions, menu navigation, and configuration. The VesselView 903 is covered under the Mercury engine warranty — not the WaterCar vessel warranty.

Swim Ladder

The WaterCar EV is equipped with a flip-down step near the transom for exiting the water if needed. A removable swim ladder is available as an accessory and mounts near the side door. The side door must remain closed and latched at all times while the vessel is in the water.

⚠ **DANGER** NEVER use the exit step or swim ladder while the outboard engine is running. Shut off the engine and remove the key before anyone enters or exits the water. Contact with a spinning propeller will cause serious injury or death. DO NOT open the side door while the vessel is in the water — opening the door while afloat creates an immediate flooding and capsize hazard.

Hinged Bow Cushions

The WaterCar EV is equipped with hinged bow cushions that provide seating and lounging area when the vessel is at rest or at idle. The bow cushions are hinged for easy access to the bow storage compartment beneath. Always close and secure the bow cushions before operating the vessel.

⚠ **WARNING** The bow area is a working deck — it is intended for use only while mooring, anchoring, loading, or when the vessel is at rest. NEVER allow passengers to occupy the bow area while the vessel is underway. Passengers in the bow are at risk of being thrown overboard by sudden changes in speed or direction.

Canopy Top

An optional canopy top is available for the WaterCar EV, providing shade and light weather protection for cockpit occupants. When installing or removing the canopy top, follow the manufacturer's instructions included with the accessory. Ensure all support straps are taut and secure before operating the vessel. A loose canopy frame can damage navigation lights and other equipment. Remove the canopy top before trailering at highway speeds unless specifically rated for trailering.

5.14 Pre-Launch Checklist

Complete this checklist before every water operation. Do not launch if any item fails.

Vessel & Equipment

- Hull condition — inspect for cracks, damage, or abnormal wear
- Drain plug — installed and secured
- Transfer tube drainage — confirm water can flow freely through the transfer tube and is not blocked. Check at both ends.
 - Bilge — dry or minimal water; bilge pump functional
 - All hatches and access covers — closed and secured
 - Windshield — clean and undamaged
 - All safety labels visible and legible
 - Fire extinguisher — gauge in green zone, pin intact
 - Visual distress signals — onboard and within expiration date
 - Sound device (horn/whistle) — functional
 - Anchor and line — onboard if required
 - First aid kit — onboard and stocked

PFDs & Safety Equipment

- One USCG-approved PFD for each person onboard — correct size, accessible
- At least one throwable Type IV PFD onboard
- Kill switch lanyard — present and attached to operator
- Float plan filed with responsible person ashore
- VHF radio or cell phone onboard for emergency communication

Outboard Engine

- Engine oil level — within spec (refer to Mercury manual)
- Fuel level — sufficient for planned operation plus reserve
- No fuel leaks — inspect fuel line, fittings, tank
- Propeller — undamaged, securely attached, prop nut/cotter pin intact
- Propeller area — clear of debris, lines, and obstructions
- Engine tilt — positioned correctly for launch depth
- Kill switch — functional; lanyard attached to operator

Electrical & Battery Systems

- 48V battery — charged and powered ON
- 12V battery — charged; terminals clean and tight
- Navigation lights — test all lights (port, starboard, stern, anchor)
- Bilge pump — test manual override

- Transfer tube — confirm free water flow through the transfer tube. Clear any blockage before water operation.
 - Horn — functional
 - Shore power disconnected — vessel fully unplugged before launch

Launch Site Assessment

- Launch site — assessed for depth, obstacles, current, and traffic
- Wind and weather — checked; conditions appropriate for operation
- Other vessel traffic — observed; launch approach is clear
- No-wake zones, speed limits, and restricted areas — identified

⚠ WARNING

This checklist does not replace operator judgment. If any condition creates doubt about safety, do not launch.

5.15 Water Operation

Navigation Rules — Overview

Situation	Rule
Meeting head-on	Both vessels alter course to starboard (right). Pass port-to-port.
Crossing situation	Vessel with the other on its starboard side gives way.
Overtaking	Overtaking vessel gives way. Stand-on vessel maintains course and speed.
Sound signals — 1 blast	I am altering course to starboard.
Sound signals — 2 blasts	I am altering course to port.
5 or more short blasts	Danger signal — intent or action of other vessel not understood.
Restricted visibility	Proceed at safe speed. Sound fog signal — one prolonged blast every 2 minutes.

Full Navigation Rules: www.navcen.uscg.gov

Speed & Wake

Operate at safe speed at all times. Observe all posted speed limits and no-wake zones.

⚠ CAUTION

Excessive wake can damage other vessels, docks, and shoreline property. You are responsible for your wake.

Weather Assessment

⚠ DANGER

DO NOT operate in severe weather conditions. Seek safe harbor before weather deteriorates. A sudden change in wind direction or speed, or an increase in wave height, indicates deteriorating conditions — return to shore immediately.

Before departure: Check NOAA weather radio, VHF Channel 16, or a marine weather service. Confirm wind speed, direction, wave height, and visibility forecast for the duration of your planned operation.

While underway: Monitor conditions continuously. If fog: slow down, post a lookout, sound one prolonged blast on horn every 2 minutes. If lightning approaches: return to shore immediately.

Passenger Safety on Water

⚠ WARNING

Never allow passengers to sit on the bow, gunwales, or any non-designated seating area while underway. All passengers must remain fully seated in designated seating positions at all times.

Outboard Throttle & Trim

The Mercury® outboard throttle/shift lever controls both direction and engine speed. Always shift to Neutral completely before reversing direction. Never shift from Forward to Reverse at high speed.

Trim adjustment: Trim down to help the vessel get on plane, then trim up gradually as speed increases to reduce drag. Too much trim up = bow rises, stern squats, rough ride. Too much trim down = bow plows, spray over bow. Refer to the Mercury owner's manual for detailed trim guidance.

Understanding Trim Angle Adjustments

The correct trim angle depends on boat speed and environmental conditions. Adjusting the trim angle affects how the vessel rides through the water.

Trimming In (Down): Brings the propeller closer to the transom. Pushes the bow down and raises the stern. Useful at lower speeds for better control and in rough water.

Trimming Out (Up): Raises the bow and lowers the stern. Increases speed and fuel efficiency at cruise. Be cautious — trimming out too far can lift the bow excessively, reducing control and visibility.

Neutral Trim: Flattens the hull for a balanced ride. Ideal for cruising at moderate speeds.

⚠ CAUTION

Avoid extreme trim adjustments. Trimming too far in pushes the bow into the water, making handling difficult and causing spray. Excessive trimming out lifts the bow too high, reducing control. Both extremes significantly alter handling.

Setting Trim in Calm Conditions

- Start with trim at approximately 40-50% on the Mercury display.
- Begin by trimming the engine all the way in, then slowly trim up as speed increases.
- Boat speed will increase as the most efficient trim angle is found.
- If the boat starts porpoising (bow moving rhythmically up and down), speed decreases, or cavitation occurs (air around the propeller causing erratic speed changes), the outboard is trimmed out too far. Trim in slightly.

Adjusting Trim in Choppy Waters

- In rougher conditions, trim in to flatten the hull angle for better control and passenger comfort.
- If conditions worsen, reduce throttle and adjust trim to maintain control.

Anchoring

65. Select anchorage — confirm adequate depth and swinging room.
66. Approach at slow speed, heading into wind or current. Shift to Neutral.
67. Shut down the engine before going forward to deploy anchor.
68. Lower anchor slowly — do not throw. Let out scope at minimum 5:1 ratio — increase to 7:1 in wind or current.
69. Confirm anchor is set — apply reverse to drag anchor gently into seabed.
70. Display anchor light if remaining at anchor after sunset in a navigable waterway.

Mooring

When mooring to a dock, float, or mooring buoy, approach at slow speed from downwind or down-current. Have lines and fenders ready before approach. Never step from a moving vessel to a dock.

⚠ CAUTION

Shut down the engine before any person steps off the vessel. Never allow passengers to step off while the engine is running or the vessel is still moving.

Man Overboard (MOB) Procedure

⚠ DANGER

IF ANYONE FALLS OVERBOARD: Shout "MAN OVERBOARD" — assign a lookout to keep continuous visual contact. Throw a throwable PFD immediately. Shut down the engine. Approach the person carefully from downwind. Stop engine completely before the person is within propeller reach. Recover the person — check for injury. Contact emergency services if needed. NEVER approach a person in the water with the engine running.

USCG Emergency: VHF Channel 16 | Call or text 911 | USCG Rescue Coordination: 1-800-368-5647

Risk of Loss of Stability

Stability is the vessel's ability to return to an upright position after being tilted by waves, wind, or other forces. Loss of stability can lead to capsizing, swamping, or sinking. Understanding the factors that affect stability is essential for safe operation.

Weight distribution is a primary concern. Uneven weight distribution — whether from passengers, gear, or fuel — can cause the vessel to list to one side, increasing the risk of capsizing. Balance the load evenly and avoid sudden shifts in weight. Overloading the vessel beyond its rated capacity lowers the freeboard (the distance from the waterline to the deck), making it more susceptible to taking on water in rough conditions.

Environmental conditions play a significant role. High winds, large waves, and strong currents can challenge stability even in well-designed vessels. Adjust speed and heading to minimize the impact of these forces. Avoid operating in adverse weather whenever possible. Stay informed about weather forecasts and water conditions.

The vessel's design and condition are fundamental to stability. Conduct regular maintenance checks to ensure the hull, bilge pumps, and drainage systems are in good working order. Any modifications or repairs should be performed according to WaterCar specifications to avoid compromising stability. Familiarize yourself with the vessel's performance characteristics and design limitations.

⚠ WARNING

Always adhere to the recommended load limits. Ensure the load is evenly distributed, with particular attention to keeping weight low in the vessel. Stability is significantly compromised by any weight added higher up.

Protection from Falling Overboard

Falling overboard is one of the most common and potentially dangerous boating accidents. Implementing prevention measures is essential for the safety of all persons onboard.

- Always ensure everyone onboard wears a properly fitted life jacket.
- Maintain a clutter-free deck. Stow loose gear securely to avoid tripping hazards.
- All passengers must remain seated while underway. No standing, sitting on gunwales, or leaning over the side.
- Brief all passengers on safety procedures before departure, including MOB response and emergency equipment location.
- The operator must avoid sudden or sharp maneuvers that could cause passengers to lose balance.
- Keep a watchful eye on all passengers, especially children and those less experienced on the water.

Environmental Responsibilities**⚠ WARNING**

Federal law prohibits the discharge of fuel, oil, or oily waste into U.S. navigable waters. Violators are subject to substantial civil and criminal penalties.

- Use rags or absorbent materials to clean up any fuel or oil spill — never rinse into the water.
- Do not use the bilge pump to discharge oily bilge water overboard.
- Avoid overfilling the fuel tank — stop before full to allow for thermal expansion.
- Observe all posted no-wake zones. You are responsible for any injury or damage caused by your vessel's wake.

As an amphibious vehicle owner, understanding and adhering to environmental protection regulations is essential. These regulations preserve natural habitats and ensure continued access to waterways for all users.

Responsible Travel

- On land, use designated paths, trails, and roads. Avoid widening trails or causing unnecessary damage. Cross streams only at designated fords.
- On water, use designated waterways and launch areas to minimize environmental impact.

Respecting Others

- Respect the rights of others, including private property owners and recreational users. Yield as appropriate.
- On the water, show respect to anglers, swimmers, skiers, divers, and those near shore. Manage your wake.

Avoiding Sensitive Areas

- Avoid meadows, lakeshores, wetlands, and stream banks at speed. Stay on designated routes.
- Avoid shallow areas and shorelines at high speed to prevent erosion and disturbance to aquatic life.

Managing Oil and Fuel

- Investigate the source of any oil leak immediately. Always have oil-absorbing cloths onboard to manage spills.
- Never dispose of oil, paint, fuel, or chemicals into the water or on the ground.
- Retain all waste until it can be properly disposed of ashore.

Minimizing Wake and Noise

- Adjust speed to water conditions. Excessive wake can damage other vessels, docks, and shoreline property.
- Avoid running the engine unnecessarily or at higher speeds than conditions require. Minimize noise pollution for the enjoyment of all waterway users.

5.16 Outboard Engine

⚠ NOTICE

The Mercury® outboard engine is covered by a separate Mercury owner's manual supplied with your vehicle. The Mercury manual is the authoritative reference for all engine operation, service, maintenance intervals, and specifications. This section provides operational guidance specific to the WaterCar EV installation.

✓ CONFIRMED

The WaterCar EV Marine Package is compatible with Mercury® outboard engines as specified on the capacity plate. The specific engine model and horsepower rating installed on your vessel is documented on the capacity plate (Section 5.5). The Mercury engine serial number is located on the engine mounting bracket. Refer to the Mercury owner's manual included in your Owner's Manual Packet for all engine-specific operating procedures, maintenance schedules, and warranty information.

Fuel System

Specification	Value
Fuel Type	Unleaded gasoline — minimum octane per Mercury specifications
Fuel Tank Capacity	18 Gallons
Ethanol Content	E10 (10% ethanol) maximum. E15 and E85 are NOT approved.
Fuel Fill Location	Deck-mounted fuel fill — cap must be secured after filling

⚠ WARNING

DO NOT USE E15, E85, OR ANY FUEL BLEND WITH MORE THAN 10% ETHANOL. High-ethanol fuels damage marine engine fuel system components and void the Mercury warranty.

Fuel System Overview

The fuel system delivers fuel from the gas tank to the Mercury® outboard engine. The 18-gallon gas tank is CARB (California Air Resources Board) approved, meeting standards for evaporative emissions. The tank is constructed from high-density polyethylene, which is resistant to corrosion and impact in the marine environment. It features an integrated fuel gauge for monitoring fuel levels from the console.

Fuel system components include the fuel lines, and the built-in fuel pump and fuel filter of the outboard engine. Fuel lines are made of reinforced rubber or marine-grade materials rated for the marine environment.

The fuel filler is located on the transom. When fueling, use unleaded gasoline meeting Mercury octane specifications. Do not fill the tank to maximum capacity — leave room for thermal expansion. Close the fuel cap firmly but avoid over-tightening to prevent damage to seals.

Fuel System Maintenance

- Regularly inspect fuel lines for signs of wear, cracking, or damage. Replace as necessary.
- The fuel filter and pump are integrated into the Mercury® outboard — follow manufacturer recommendations for inspection and replacement.
- Regularly check for fuel leaks and address any issues immediately.
- At the start of each season, inspect the entire fuel system before first use.

Engine Starting Procedure

71. Confirm pre-launch checklist complete. Engine in Neutral.
72. Confirm kill switch lanyard attached to operator's wrist or PFD.
73. Confirm vessel floating freely with adequate depth under propeller.
74. Prime fuel system if required by Mercury starting instructions.
75. Start the engine following Mercury starting procedure.
76. Verify cooling water tell-tale flowing within 30 seconds. If not — shut down immediately.
77. Allow engine to warm up at idle for 1–2 minutes before applying throttle.

⚠ WARNING

Never start the outboard engine with persons near the propeller or in the water behind the vessel.

New Engine Break-In

If your vessel is delivered with a new Mercury engine, a break-in period is required before operating at full throttle for extended periods. Refer to the Mercury owner's manual for the specific break-in procedure and duration.

During the initial break-in period, avoid extended idling. Vary engine speed frequently throughout the break-in.

For the first two hours of operation: operate at varied throttle settings up to approximately 4,500 RPM (about three-quarters throttle). Include brief full-throttle bursts of no more than one minute every ten minutes.

For the next eight hours: avoid continuous full-throttle operation for longer than five minutes at a time.

Use only the fuel grade, oil type, and maintenance intervals specified in the Mercury documentation. Following these steps ensures optimal performance, fuel efficiency, and long-term reliability.

Freshwater Flushing — After Every Use

78. Remove vessel from water. Connect flush adapter (earmuffs) to engine water inlets.
79. Connect garden hose — do not turn on water yet. Start engine at idle.
80. Turn on freshwater supply — confirm water flow from tell-tale.
81. Run engine at idle with freshwater flowing for a minimum of 5 minutes.
82. Shut down the engine first, then turn off water. Disconnect flushing equipment.

⚠ CAUTION

Never run the engine at high RPM during flushing. Always confirm water is flowing before running. Always shut engine down before turning off water supply.

Engine Shutdown

83. Reduce throttle to idle. Shift to Neutral. Allow to idle for 1–2 minutes.
84. Shut down engine per Mercury procedure.
85. Remove kill switch lanyard only after engine is fully stopped.
86. Tilt engine to transport/storage position as appropriate.

Engine Service Schedule

Mercury Marine global dealer locator: www.mercurymarine.com

Service Item	Interval / Notes
Engine oil and filter	Per Mercury schedule — typically every 100 hours or annually
Gear lube	Check before each season; replace per Mercury schedule
Spark plugs	Per Mercury service schedule
Fuel filter	Per Mercury schedule or if fuel quality issues arise
Water pump impeller	Per Mercury schedule — typically every 2 years or 200 hours
Propeller	Inspect before each use; replace if bent, cracked, or missing material
Anodes (zinc)	Inspect seasonally; replace when 50% consumed
Winterization	Required in freezing climates — refer to Mercury manual
	<p>Whale Tail (Hydrofoil)</p> <p>Rear Flip Plates</p> <p>The vessel is equipped with spring-loaded rear flip plates that automatically assist with planing attitude and ride quality. The flip plates are passive and require no operator adjustment — they deploy and retract automatically based on water pressure. No maintenance or inspection is required beyond verifying they are not damaged or obstructed.</p>

The outboard is equipped with a whale tail hydrofoil mounted on the lower unit anti-cavitation plate. The whale tail improves hole shot performance, helps the vessel get on plane faster, and enhances low-speed stability. No adjustment or maintenance is required. If the whale tail is damaged or missing, contact WaterCar for replacement.

Outboard Oil Requirements

The oil reservoir for the Mercury® outboard is located in the rear transom locker. An oil cap is located on the top of the transom, and oil levels can be inspected from the rear hatch on the front face of the transom.

Recommended oil: Mercury or Quicksilver NMMA FC-W certified 4-Stroke outboard oil. As alternatives: Mercury or Quicksilver SAE 25W-40 Mineral Marine 4-Stroke Engine Oil or SAE 25W-40 Synthetic Blend Marine 4-Stroke Engine Oil.

If recommended Mercury or Quicksilver oils are not available, a major outboard manufacturer's brand of NMMA FC-W certified 4-Stroke outboard oil of similar viscosity may be used.

5.17 Marine Maintenance Schedule

Interval	Item	Action
After salt/brackish water use	Outboard flush	Flush with fresh water — Section 5.16
After every use	Post-water inspection	Complete full checklist — Section 6.4
After every use	Bilge	Pump out bilge; inspect for unusual water intrusion
After every use	Propeller	Inspect for damage, line wrap, or missing material
After every use	WD-40	Spray all exposed metal, hinges, and connections
Monthly	Hull exterior	Inspect for cracks, blistering, abrasion, or impact damage
Monthly	Navigation lights	Clean lenses; inspect wiring and connections
Monthly	Electrical connections	Inspect marine connections for corrosion
Monthly	Bilge pump	Test automatic and manual operation
Monthly	Zinc anodes	Inspect; replace when 50% consumed

	• Bellow clamps — inspect and confirm tight. Loose bellow clamps can allow water intrusion into the hull through wheel openings.	
Monthly	Zerk fittings	Grease all hydraulic pivot points — included grease gun
Seasonally	Hull bottom	Inspect for fouling, blistering, and coating condition
Annually	Fire extinguisher	Inspect charge, pin, nozzle; replace if expired or discharged
Annually	Visual distress signals	Check expiration dates; replace before expiry
Annually	PFDs	Inspect for damage, fading, mildew; confirm USCG approval
Per Mercury schedule	Outboard service	Refer to Mercury manual and Section 5.16

5.18 Hull Inspection & Corrosion Prevention

- Inspect welds, seams, and rivets for cracks or separation.
- Check hull bottom for deep scratches, gouges, or dents.
- Inspect transom area for stress cracks or deformation.
- Check hull-to-deck joint for separation or water intrusion.
- Look for osmotic blistering (bubbles under paint/coating).
- Inspect drain plug fitting for condition and seal integrity.

Corrosion Prevention — Saltwater Operation:

- Flush the entire vessel with fresh water after every salt or brackish water operation.
- Apply WD-40 or corrosion inhibitor to electrical connections, fasteners, and mechanical linkages after each saltwater use.
- Inspect and replace zinc sacrificial anodes seasonally or when 50% consumed.
- Rinse and dry all seat belts, upholstery, and fabric components after saltwater exposure.

Bottom Painting & Antifouling

If the WaterCar EV will be kept in the water for extended periods, bottom painting with an appropriate marine antifouling paint may be necessary to control biological growth (fouling) on the hull. Bottom painting is the owner's responsibility and is not covered under the WaterCar warranty.

- Before painting, the hull must be thoroughly cleaned, degreased with a marine surface prep solvent appropriate for aluminum, and sanded with appropriate grit paper. Follow the paint manufacturer's preparation instructions for aluminum substrates.
- Do not paint over zinc anodes or sacrificial metals. This will render them ineffective and accelerate corrosion of underwater metal components.
- Leave a minimum of 3/4 inch unpainted around all outboard engine components. Some antifouling paints contain metals that can cause corrosion of aluminum engine parts.
- If bottom painting a previously painted hull, test compatibility of the new paint with the existing coating before application. Incompatible paints will not adhere or may lift the existing coating.

- Bottom painting may affect vessel performance. If maximum engine RPMs drop below the recommended operating range after painting, re-propping may be required. Consult your outboard dealer.

⚠ DANGER Bottom paint contains toxic chemicals. Follow all manufacturer safety precautions. Use proper respiratory protection, ventilation, and protective equipment. Dispose of all painting materials in accordance with local environmental regulations.

5.19 Seasonal Layup

87. Flush outboard with fresh water; winterize per Mercury manual.
88. Charge both batteries to 50% or above; turn batteries off for storage.
89. Drain bilge completely. Flush and rinse hull, wheel wells, and all exterior surfaces.
90. Inspect and treat zinc anodes; replace if significantly consumed.
91. Cover vessel to protect from UV and debris.
92. Check fire extinguisher, VDS expiration dates, and PFD condition.
93. Charge batteries at least once every 6 months during storage period.

⚠ NOTICE

Upon returning to service after seasonal layup: charge both batteries fully, inspect all systems, complete the Pre-Launch Checklist (Section 5.14) before any water operation, and verify Mercury annual service is current.

5.20 Marine Specifications

Subject to change without notice. Verify against capacity plate and Mercury documentation for your specific unit.

Speed on Water: 35 MPH / 56.32 KM/H

Fuel Capacity: 18 Gallons (Gas) / 68 Liters

Range on Water: 80 Miles / 130 KM (estimated, conditions dependent)

Overall Length (LOA): 19.5 FT / 6 M

Waterline Length (LWL): 18 FT / 5.4 M

Beam: 6.5 FT / 1.98 M

Dry Weight: 2,000 lbs / 907 kg (Marine Package with outboard — weight varies by outboard engine model)

Maximum Persons on Water: Per capacity plate (see Section 5.5)

Maximum Weight on Water: Per capacity plate (see Section 5.5)

Outboard: Mercury — confirm exact model on your unit

SECTION 6

Amphibious Operation

Requires familiarity with both Section 4 (LSV) and Section 5 (Marine)

6. Amphibious Operation

This section covers the unique amphibious capabilities of the WaterCar EV — the hydraulic wheel system (LaunchMode™), land-to-water and water-to-land transitions, and operating procedures specific to the amphibious mode. Read Sections 4 and 5 completely before reading this section.

⚠ WARNING

Amphibious transition operations require full attention from the operator. Do not attempt transitions in unfamiliar locations, in poor visibility, in rough surf, or in strong tidal currents until you are fully proficient in calm, controlled conditions. Build your skills progressively.

For a video demonstration of the WaterCar EV amphibious transition procedure, visit:
<https://www.youtube.com/watch?v=wdKs5TyZWGE>

✉ Letter from the WaterCar Team — Delivery Notes & Quick Start

Congratulations — you are now officially a proud owner of a WaterCar EV and part of the WaterCar family. The following notes are written from our delivery team to help you get started with confidence. Always follow the detailed procedures in this manual for formal operation — these notes are a practical companion, not a replacement.

Please remember: the WaterCar EV is a dual-purpose vehicle — part boat and part street-legal vehicle. It will sound and drive differently than anything else in the world, and you will be operating it in situations most vehicles cannot handle, such as transitioning in and out of the water.

Think of it like this: you would not jump into a tractor, hovercraft, or helicopter without learning the controls first. The same applies here. If you have no boating experience, we do not recommend operating on water until you gain some. Be sure to follow all applicable laws in your area — a boater's license or driver's license may be required depending on your jurisdiction.

Service & Support

The WaterCar EV has been intentionally engineered to be supported locally anywhere in the world, using proven automotive and marine systems rather than proprietary or dealer-only components. This means routine service and maintenance can be handled by a trusted local automotive or marine mechanic, or by owners who are mechanically inclined. We highly recommend that owners have access to a qualified local mechanic as part of the ownership experience.

WaterCar provides direct, real-time remote support via phone and video, working closely with owners and their selected service providers. In practice, most questions and service needs are resolved this way.

Contact the Sales/Service Department at (714) 251-6687 — call or text.

Quick Start — Powering On

The WaterCar EV has two lithium batteries: a 48V main drive battery and a 12V accessory battery. Both must be ON for operation.

- Press the button on each battery until lights illuminate. The 12V shows four green lights when full (fewer lights = lower charge). The 48V charge level is displayed on the gauge near the helm.
- Turn the two large red master switches beside the driver's seat to ON.
- The 48V gauge will show percentage remaining. The 12V gauge reads approximately 13V when charged.

Once both batteries and switches are on, the vehicle is powered.

Quick Start — Dash Layout

- Right (starboard) side — Road driving controls: Forward/Neutral/Reverse toggle, turn signal buttons, ignition key for electric motor.
- Left (port) side — Marine controls: Mercury ignition key and safety lanyard, throttle/shift lever, Mercury display, accessory buttons (screen, lights, bilge, horn).

Quick Start — Driving on Land

- Confirm batteries on, master switches on, ignition key turned on (you will hear the controller click).
- Use the Forward/Neutral/Reverse toggle to select direction.
- Release the parking brake lever (left of seat). If engaged, the motor will strain against it.
- Use turn signals as needed. Short presses blink briefly; longer presses keep them on until pressed again.

Operation is similar to a golf cart — smooth throttle, gradual stops, stay under 25 MPH.

Quick Start — Entering the Water

- Ensure safety lanyard is attached and switch is in RUN position.
- Test the outboard tilt to confirm it has power.
- Approach the water ramp perpendicular (straight in) — never at an angle.
- Drive slowly into the water. Keep light pressure on the throttle so regenerative braking does not stop you on the ramp.
- Once floating: lower the outboard carefully until submerged. Start the outboard (never run it dry). Check for the cooling water stream.
- Navigate a safe distance from shore before raising wheels.
- Shut off the land motor (ignition key on right side).
- STRAIGHTEN THE WHEELS — confirm by looking back at the outboard. If it is centered, the wheels are straight.
- Raise REAR wheels first, then FRONT wheels. Hold each switch until the pump tone changes (approximately 20 seconds per axle).

You are now in boat mode.

Quick Start — Operating in Boat Mode

- Set trim to approximately 45 on the Mercury display and accelerate to 5,500-6,000 RPM to get on plane. Back off once on plane and settle into cruise speed.
- If the vessel is not getting on plane: check that ALL wheels are fully retracted (this is like an airplane — landing gear must be fully up for efficient operation). Avoid weight in the bow. Minimize gear forward. Do not sit in the forward seats while getting on plane.

When properly configured and loaded, the WaterCar EV handles and planes like a conventional 18-foot recreational boat.

Quick Start — Returning to Land

- Line up with the ramp perpendicular (straight on) from a safe distance.
- STRAIGHTEN THE WHEELS — confirm by looking at the outboard.
- Lower FRONT wheels first, then REAR wheels. Hold switches until pump tone changes.
- Raise outboard partially (trim approximately 80-85) — still in water for cooling but high enough to avoid hitting bottom.
- Turn land motor key ON and set Forward on the directional switch before reaching shore.
- Approach slowly. Let wheels contact the ramp, then gently press throttle to drive up.
- Once wheels have traction: turn off the outboard (never run it dry). Continue driving up ramp.

Practical Notes from the Delivery Team

- Batteries — We ship both fully charged, but transport drivers have occasionally left them on during shipping. If batteries arrive low, this is normal — a full charge cycle restores them completely.
- Tires — Tires may rub slightly on very sharp turns. This is normal due to suspension travel and is not a defect.
- Parking on slopes — On steep slopes or when leaving the vehicle unattended, lower the bow so the hull rests on the ground (front wheels slightly off). This prevents rolling and makes entry and exit easier.
- Lowering vehicle on land — Only lower the FRONT hydraulics. Lowering the rear risks the hull contacting the outboard.
- Controller faults — Some faults can be cleared by cycling the key OFF, waiting 3 seconds, then ON. A directional fault can occur if Forward and Reverse are toggled too quickly. This is normal behavior of the self-protecting electronic controller.
- Canopy setup — If your vehicle includes a canopy, contact WaterCar for setup photos. One bar must slide fully down, the other fully up for proper fit.
- WD-40 — Use it generously and often. After every water use, spray all exposed metal components. Multiple cans are included in your care package for a reason.

⚠ NOTICE

This quick start guide is a practical companion to the full Owner's Manual. For complete operating procedures, safety warnings, regulatory information, and maintenance schedules, always refer to the applicable sections of this manual.

6.1 The Two-Propulsion System

The WaterCar EV operates two completely independent propulsion systems that must be managed in sequence during transitions:

Mode	Propulsion	Controlled By	Key Rule
LAND	48V electric motor	Accelerator pedal + FNR switch	Electric drive must be OFF before water entry
WATER	Mercury® outboard engine	Throttle/shift lever at helm	Outboard must not be started until prop is submerged
TRANSITION	Both systems briefly	Operator coordinates both	Never engage electric drive while floating; never run outboard out of water

6.2 Hydraulic Wheel System (LaunchMode™)

The WaterCar EV road wheels retract hydraulically for water operation. The hydraulic system is controlled by two rocker switches on the PORT (far left) side of the dashboard.

Controls

- FRONT switch — controls the front wheels.
- REAR switch — controls the rear wheels.
- Button UP = Wheels UP (retracted). Button DOWN = Wheels DOWN (deployed).
- Easy mnemonic: "Wheels up, button up."

⚠ NOTICE

Each hydraulic cycle takes approximately 20 seconds. Hold the rocker switch continuously until the pump tone changes — this confirms wheels are fully up or fully down. Do not release the switch early. Releasing early leaves wheels in an intermediate position.

⚠ DANGER

ALWAYS confirm the steering wheel is centered and wheels are pointed STRAIGHT before operating any hydraulic switch. Verify alignment by looking back at the outboard — if the outboard is centered, the wheels are straight. Raising or lowering with turned wheels will cause the wheels to contact the hull walls and cause structural damage.

Wheel Position Reference Table

Operating Mode	Required Wheel Position
Road / Land Driving	ALL WHEELS FULLY DOWN
Water / Boat Mode	ALL WHEELS FULLY RETRACTED
Entering Water (ramp)	Wheels FULLY DOWN until floating — raise REAR first, then FRONT
Exiting Water (ramp)	Lower FRONT first, then REAR — before hull contacts ramp
Parked on Land — Level	All wheels fully down. Engage park brake.
Parked on Land — Slope	Lower FRONT hydraulics only so bow hull rests on ground. Rear stays up. Prevents rolling on grades.

Wheel Alignment Rule

ALWAYS confirm the steering wheel is centered before raising or lowering wheels. You can verify wheel alignment by looking back at the outboard — if the outboard is centered and straight, the wheels are straight. Never operate hydraulic switches with the steering wheel turned.

On-Land Rear Hydraulics

When the WaterCar EV is parked on land, only lower the FRONT hydraulics if you want to lower the bow onto the ground (for steep slope parking). Do NOT lower the rear hydraulics while on land — lowering the rear risks the hull contacting the outboard.

Getting on Plane — Wheel Position

All four wheels must be FULLY RETRACTED before planing is possible. Even one wheel partially down creates significant underwater drag and prevents the hull from rising onto plane.

94. Confirm all wheels are fully retracted — pump tone confirmed on both front and rear.
95. Set outboard trim to approximately 45 on the Mercury display screen.
96. Advance throttle smoothly to 5,500–6,000 RPM.
97. Once on plane, back off throttle slightly and settle into cruise speed.
98. Adjust trim as needed for optimal running angle – typically 65 trim

Troubleshooting — vehicle not getting on plane:

- Wheels not fully retracted — steering wheel is strait, confirm pump tone, re-run hydraulic cycle on all four wheels.
- Excessive weight in the bow — redistribute passengers and gear rearward.
- Excessive total load — reduce payload.
- Outboard trim incorrect — return to 45 and adjust progressively.

6.3 Land-to-Water Transition — Full Procedure

⚠ WARNING

Complete the Pre-Launch Checklist (Section 5.14) in full before beginning this procedure. Never begin water entry with an incomplete or failed checklist.

Launch Site Selection

- Gradual, firm, unobstructed entry slope — avoid loose sand, steep drops, or submerged obstacles.
- Adequate water depth at the end of the ramp — sufficient for the outboard engine at operating tilt.
- Clear of vessel traffic, swimmers, and obstructions in the entry path.
- Wind direction and current — assess impact on entry control.
- Confirm exit route before entry.
- A hard slipway or concrete boat ramp is the preferred entry site. If unavailable, ensure the surface is firm and stable — avoid marshy, muddy, or soft ground that could trap the vehicle.
- Check for underwater hazards that could damage the hull or cause the vehicle to become beached — rocks, pilings, debris, or sudden depth changes.
- Avoid sites with undercuts or eroded banks — the edge may collapse under the vehicle's weight.
- Be aware of tidal range and tidal currents. A site accessible at high tide may be impassable at low tide. Fast tidal currents can push the vehicle off course during entry or exit.

Water Entry Sequence

Follow this sequence exactly. Each step must be confirmed complete before proceeding to the next.

99. **APPROACH:** Drive to the water's edge at low speed. Stop completely before any part of the hull contacts the water.
100. **ENGINE & DRIVE OFF:** Turn the electric motor key switch to OFF. Place the FNR switch in Neutral. Confirm the 48V drive system is off.
101. **OCCUPANTS & GEAR:** Ensure all occupants are seated and secured. Stow all loose gear. Confirm all persons have PFDs accessible.
102. **KILL LANYARD:** Operator attaches kill switch lanyard to wrist or PFD before proceeding.
103. **WHEEL RETRACTION — REAR FIRST:** Using the REAR hydraulic switch, retract the rear wheels. Hold switch until pump tone changes — this confirms rear wheels are fully up.
104. **WHEEL RETRACTION — FRONT:** Using the FRONT hydraulic switch, retract the front wheels. Hold switch until pump tone changes — this confirms front wheels are fully up.
105. **OUTBOARD TILT:** Lower the outboard motor to operating angle. Set trim to approximately 45 on the Mercury display screen.
106. **CONTROLLED ENTRY:** Gradually and slowly move the vehicle into the water. Maintain steering control throughout.
107. **FLOTATION CONFIRMATION:** Once the hull is fully in the water, confirm the vessel is floating freely and level. Check bilge — any unexpected water intrusion requires immediate return to shore.
108. **ENGINE START:** With vessel floating and stable, start the Mercury® outboard following the procedure in Section 5.16.
109. **COOLING WATER CHECK:** Verify the engine cooling water tell-tale is producing a steady stream within 30 seconds. If not — shut down immediately.
110. **CAST OFF:** Release any mooring lines. Confirm path ahead is clear before engaging throttle.

⚠ DANGER

NEVER start the outboard engine with the propeller out of the water. This causes immediate cavitation damage and will destroy the lower unit. Confirm the prop is fully submerged before starting.

⚠ CAUTION

If the vessel does not float level, lists to one side, or takes on water during entry, return to the launch site immediately. Investigate and correct before attempting water operation.

6.4 Water-to-Land Transition — Full Procedure

Water exit is the transition from vessel operation back to road/land operation. Select the exit site before approaching — confirm it is clear, firm, and of appropriate grade before committing to the exit.

Exit Site Assessment

- Firm, stable, gradual surface — no loose sand, soft ground, or steep grade.
- Adequate approach depth — no submerged obstructions.
- Clear of other vessels, swimmers, and pedestrians.
- Road surface above exit is clear.

Water Exit Sequence

111. **ENGINE SHUTDOWN:** Shut down the Mercury® outboard engine completely. Confirm the engine has stopped and the propeller is no longer rotating before proceeding.
112. **APPROACH:** Allow the vessel to drift or use minimum movement to align with the exit ramp. Do not use the outboard engine to push the vessel onto the ramp.
113. **TILT OUTBOARD:** Tilt the outboard motor to the full-up position to protect the engine from contact with the ramp surface. Lock in place.
114. **WHEEL DEPLOYMENT — FRONT FIRST:** When the hull contacts the ramp and the vessel is stable, use the FRONT hydraulic switch to deploy the front wheels. Hold switch until pump tone changes — front wheels fully down.
115. **WHEEL DEPLOYMENT — REAR:** Using the REAR hydraulic switch, deploy the rear wheels. Hold switch until pump tone changes — rear wheels fully down.
116. **CONFIRM ALL WHEELS LOCKED:** Visually and physically confirm all four wheels are deployed and locked before engaging electric drive power.
117. **ELECTRIC DRIVE ON:** Turn the electric motor key switch ON. Power on the 48V battery. Engage the FNR switch to Forward.
118. **DRIVE OUT:** Slowly drive the vehicle up and off the ramp to the staging area. Maintain low speed.
119. **STOP AND ASSESS:** Stop the vehicle clear of the ramp and water's edge. Set the park brake. Perform the post-water inspection below before driving on public roads.

Post-Water Inspection — Before Road Operation

Item	Action
Bilge	Check bilge — pump out any accumulated water before road operation.
Hull exterior	Inspect hull for damage, impact marks, or abnormal wear.
Wheels and tires	Confirm all four wheels are fully deployed and locked. Inspect tires for damage.
Wheel nuts	Check wheel nut tightness after any significant water operation.

Brakes	Test brake pedal — confirm firm feel. Wet brakes may require light application to dry.
Outboard	Tilt outboard to road travel position. Flush engine with fresh water (Section 5.16).
Electrical connections	Inspect accessible electrical connections for moisture or corrosion.
Battery compartments	Check for any moisture intrusion into battery enclosures.
Navigation lights	Rinse and inspect light housings.
WD-40 Treatment	Spray all exposed metal components, hinges, and connections with WD-40. <ul style="list-style-type: none"> • Seat belt hardware and buckles — spray latch mechanisms and mounting hardware with WD-40 after every water use to prevent corrosion and ensure reliable operation.

⚠ CAUTION

Do not operate the vehicle on public roads until the post-water inspection is complete and all items pass. Wet brakes, loose wheels, or mechanical abnormalities must be corrected before road operation.

6.5 Amphibious Operation in Surf & Tidal Conditions

Surf and tidal currents significantly increase the complexity and risk of amphibious transitions. Do not attempt surf launches or retrievals.

⚠ DANGER

THIS VESSEL IS NOT DESIGNED FOR OPERATION IN BREAKING WAVES OR SURF ZONES. Do NOT launch or recover through surf. Breaking waves can cause sudden loss of control, swamping, or capsize. Serious injury or death could result.

Tidal Current

- Strong tidal current creates significant steering challenges, especially during transition.
- Plan your approach to allow for current drift — aim up Current of your intended landing point.
- In strong tidal areas: deploy front wheels first, then rear to minimize steering disruption during exit.

6.6 Shallow Water Operation

- Minimum water depth to start outboard: propeller must be fully submerged — approximately 18 inches at the transom.
- If water becomes too shallow while underway, trim the outboard up progressively to prevent grounding.
- If the outboard must be trimmed fully up, the electric wheel drive can be engaged to drive the vehicle in very shallow water or onto a beach.

⚠ CAUTION

Operating the outboard in water shallow enough to contact the bottom will damage the propeller and gearcase. Always trim up as depth decreases. If you feel or hear the propeller contacting bottom, immediately trim up fully and engage wheel drive.

6.7 Operator Training Progression

WaterCar Inc. recommends all new operators follow this progressive training sequence before operating in challenging conditions.

Step 1 — Familiarization

- 120. Learn all dash controls, modes, and indicators before moving the vehicle.
- 121. Practice electric drive — forward, reverse, parking, throttle fault clearing.
- 122. Practice outboard starting, stopping, shifting, and trimming while at dock.

Step 2 — Transition Proficiency

- 123. Practice land-to-water transition 5 times until the sequence is automatic.
- 124. Practice water-to-land transition 5 times until the sequence is automatic.
- 125. Practice ramp approach and departure courtesy procedures.

Step 3 — Water Proficiency

- 126. Practice docking maneuvers at idle speed.
- 127. Practice anchoring and retrieving anchor.
- 128. Practice man-overboard response procedure.
- 129. Complete a USCG-approved boating safety course.

Step 4 — Advanced Operations (after Steps 1–3 demonstrated)

- 130. Natural beach launches and retrievals in calm conditions.
- 131. Operation in moderate wind and chop.
- 132. Night operation (confirm all navigation lights, carry redundant lighting).
- 133. Saltwater operation (requires diligent post-use rinse and flush protocol).

6.8 Pre-Season Amphibious Inspection

Before the first use of each season, conduct a comprehensive inspection of all amphibious-specific systems:

- Hull drain plug: inspect O-ring or gasket — replace if cracked, compressed, or deteriorated.
- All hull penetrations: inspect for cracks, deterioration, or loose fittings, or rubber bellows.
- Outboard tilt/trim system: operate full range — confirm smooth operation and no hydraulic leaks.
- Steering: full left-to-right sweep — confirm freedom of movement, no binding.
- Bilge pump: confirm manual and automatic operation.
- Navigation lights: confirm all operational.
- Kill lanyard: confirm kill switch function — attach lanyard and pull sharply to confirm engine cuts.
- All safety equipment: inspect PFDs, fire extinguisher, flares, sound signal — replace expired items.
- Battery connections: inspect all terminals, clean corrosion, apply dielectric grease.
- Hull exterior: inspect for stress cracks, impact damage, or coating deterioration.
- Zerk fittings: grease all hydraulic pivot points using included grease gun.

Grease Point Locations

The following locations have zerk (grease) fittings requiring regular lubrication:

- Front gear box — accessible from under the front of the vehicle.
- Front wheel hubs — one fitting per hub.
- Rear wheel hubs — one fitting per hub.
- Rear swing arm pivot points.

Apply grease until fresh grease begins to purge from the fitting seal. Do not over-grease. Wipe excess grease after application.

SECTION 7

Care & Maintenance

Applies to all configurations

7. Care & Maintenance

This section consolidates care and maintenance requirements for all WaterCar EV configurations. Regular maintenance is essential to safe and reliable operation in both LSV and Marine modes.

7.1 Master Maintenance Schedule

Interval	Item	Mode	Action
After every use	Fresh water rinse	Both	Rinse entire vehicle — mandatory after saltwater use
After every use	Outboard flush	Marine	Flush engine with fresh water — Section 5.16
After every use	Bilge inspection	Marine	Pump out bilge; inspect for unusual water intrusion
After every use	Propeller inspection	Marine	Inspect for damage, line wrap, or missing material
After every use	WD-40 treatment	Both	Spray all exposed metal, hinges, and connections
Before each use	Pre-ride inspection	LSV	Complete checklist — Section 4.6
Before each use	Pre-launch checklist	Marine	Complete checklist — Section 5.14
Monthly	Battery terminals	Both	Check for corrosion, tight connections; clean and protect
Monthly	Brake fluid level	LSV	Inspect reservoir; check for leaks
Monthly	Steering freeplay	LSV	Turn wheel lightly; confirm freeplay within spec
Monthly	Lights & signals	Both	Confirm all lights operational
Monthly	Wheel nuts	LSV	Inspect for tightness
Monthly	Zerk fittings	Both	Grease all hydraulic pivot points — included grease gun
Monthly	Hull exterior	Marine	Inspect for cracks, blistering, abrasion, or impact damage
Monthly	Navigation lights	Marine	Clean lenses; inspect wiring
Monthly	Zinc anodes	Marine	Inspect; replace when 50% consumed
Monthly	Bilge pump	Marine	Test automatic and manual operation
Every 5,000 mi	Tire rotation	LSV	Rotate all four tires

After 1st 100 mi	Wheel nut torque	LSV	Re-torque after first 100 miles and after any wheel removal
Twice yearly	Battery inspection	Both	Full removal; inspect for corrosion and case damage
Twice yearly	Hydraulic fluid	Both	Check levels in both pumps; top off if needed
Seasonally	Hull bottom	Marine	Inspect for fouling, blistering, and coating condition
Every 2 years	Brake fluid	LSV	Replace; replace sooner if contaminated
Annually	Fire extinguisher	Both	Check expiration date and condition
Annually	VDS (flares)	Marine	Check expiration dates; replace before expiry
Annually	PFDs	Marine	Inspect for damage, fading, mildew; confirm USCG approval
Per Mercury schedule	Outboard service	Marine	Refer to Mercury manual
As needed	Tread depth	LSV	Replace tires at or below 1/8 in (3 mm)
As needed	Brake pads/discs	LSV	Inspect for wear; replace at minimum thickness

Propeller Care

If you notice any damage to the propeller, address it immediately. A damaged propeller causes significant vibration that disrupts smooth operation and can lead to severe damage to the engine gearcase.

- Inspect the propeller before each water operation for dings, bent blades, cracks, or missing material.
- Check for fishing line, rope, or debris wrapped around the prop shaft.
- On a yearly basis, remove the propeller and lubricate the propeller shaft per Mercury specifications.
- Replace a damaged propeller immediately — do not operate with a bent or cracked prop.

Hydraulic Wheel System (LaunchMode™) Maintenance

The WaterCar EV is fitted with a hydraulic wheel-lift system powered by two hydraulic pumps — one for the front wheels and one for the rear. Regular maintenance is essential for reliable operation.

- Regularly check all visible hydraulic hoses and fittings for signs of leakage, abrasion, or excess wear.
- Replace any damaged hoses or fittings immediately — do not operate with leaking hydraulics.
- Check the fluid level in both hydraulic pumps monthly and refill if low. Use the manufacturer-recommended hydraulic fluid (Mercury/Quicksilver 865380A25 trim pump assembly).
- Grease all hydraulic pivot points at zerk fittings after every 10 hours of operation, or monthly, whichever comes first.
- After every water use — especially saltwater — grease all fittings, as salt accelerates grease washout.

Upholstery Care

Proper care of the marine-grade upholstery extends its life and maintains appearance.

- Remove loose dirt and debris using a soft brush or vacuum with a brush attachment before cleaning.
- Mix a solution of mild soap and water — preferably a marine-specific upholstery cleaner. Avoid harsh chemicals that can damage the fabric or stitching.
- Gently scrub with a soft cloth or sponge, paying extra attention to heavily soiled areas. Wring out excess water to prevent soaking the fabric.
- Rinse thoroughly with clean water to remove all soap residue.
- Blot with a clean, dry towel to absorb moisture. Allow the upholstery to dry completely before covering or storing — this prevents mold and mildew growth.
- For stubborn stains or mildew, use a marine-grade mildew remover following the product instructions. Apply to the affected area, let sit for the recommended time, scrub gently, and rinse thoroughly.
- Always store the vehicle with a cover when not in use to protect upholstery from UV damage and the elements.

Hull and Fittings Inspection

Periodic inspection of the hull and fittings is essential to identify damage, leakage, or loose fitment. This inspection should cover:

- Tie points and D-ring anchor points — confirm secure attachment, no cracking or deformation.
- Handles — inspect for looseness or corrosion.
- Console and engine box mountings — confirm all fasteners are tight.
- Through-hull fittings — inspect for cracks, deterioration, or leakage.
- Drain plugs — inspect O-ring or gasket condition. Replace if cracked or compressed.
- Upholstery mounts — confirm secure attachment.
- Windshield mounts — inspect for looseness or cracking.

Any fittings found to be loose or leaking must be corrected before further operation.

⚠ NOTICE

This vessel is not designed to be left in the water for extended periods. Store on land overnight and during extended periods of non-use to ensure optimal performance and longevity.

7.2 Corrosion Prevention Program

Corrosion is the primary long-term threat to the WaterCar EV — particularly after saltwater use. The vehicle's dual land/water operation creates exposure to both road chemicals and marine corrosion. Follow this program consistently.

After Every Use

- Rinse the entire vehicle with fresh water — hull exterior, wheel wells, undercarriage, and all accessible metal surfaces.

- Apply WD-40 to all exposed metal components, hinges, fasteners, and connections immediately after rinsing and drying. Keep multiple cans of WD-40 in the vehicle at all times — the care package includes 8–10 cans.
- Flush the outboard engine cooling system with fresh water per Section 5.16.

Monthly

- Apply marine-grade corrosion inhibitor (e.g., CRC 6-56, Corrosion X, or equivalent) to all electrical connections and terminal boards.
- Inspect battery terminals for corrosion — clean with baking soda solution and wire brush if found; apply dielectric grease after cleaning.
- Inspect zinc sacrificial anodes on hull and outboard — replace when 50% consumed. Saltwater use dramatically accelerates anode consumption.
- Inspect wiring harnesses for abrasion, cracking, or chafing.

7.3 WD-40 & Lubrication Program

WD-40 is the primary corrosion inhibitor for the WaterCar EV. Multiple cans are included in your care package. Apply generously after every water use and after every wash.

- Spray all hinge points, pivot points, and mechanical linkages.
- Spray all exposed fasteners, bolts, and hardware.
- Spray all electrical connector housings (exterior only — do not spray into open connectors).
- Spray the outboard engine exterior after flushing and before storage. WaterCar recommends applying WD-40 to all exposed metal components, fasteners, hinges, and connection points after every use — particularly after saltwater operation. Several cans of WD-40 are included with your vehicle shipment for this purpose.

Grease Gun — Zerk Fittings:

The WaterCar EV has multiple zerk (grease) fittings at pivot points throughout the hydraulic wheel and suspension system. Use the included grease gun to grease all fittings:

- After every 10 hours of operation — or monthly, whichever comes first.
- After every water use — saltwater use particularly accelerates grease washout.
- After any extended storage period before returning to service.

7.4 Seasonal Storage & Winterization

If the vehicle will be stored for 30 days or more:

134. Charge 48V drive battery to 50–80% state of charge — not full, not empty.
135. Fill outboard fuel tank and add stabilizer per Mercury recommendations.
136. Flush and fog outboard engine per Mercury storage procedure.
137. Charge 12V battery to 50% or above; turn battery switch to OFF for storage.
138. Remove hull drain plug and confirm bilge is completely dry.
139. Clean and dry all upholstery and canvas — prevent mildew.
140. Apply WD-40 to all exposed metal, hinges, and mechanical linkages.
141. Cover vessel with a breathable cover — not plastic or non-breathable material.
142. Place blocks under axles to keep trailer tires off the ground.

143. Charge batteries at least once every 6 months during storage.

▲ NOTICE

Never store the WaterCar EV with the bilge drain plug installed if the vehicle is outdoors. Rainwater accumulation in the bilge adds weight, can damage the bilge pump, and creates corrosion risk.

Battery Winterization

During seasonal storage or any period of non-use exceeding 60 days:

- Charge both the 48V Eco Battery and 12V Epoch® battery to at least 50% state of charge before storage.
- Turn both batteries OFF using their respective power buttons/switches.
- If storing in an area where temperatures will drop below -4°F (-20°C), remove the 12V Epoch® battery from the vessel and store indoors above freezing.
- Recharge batteries at least once every 6 months during extended storage to prevent deep discharge damage.
- Upon returning to service, charge both batteries fully before operating.

Electrical System Winterization

- Check all electrical connections and tighten if necessary.
- Spray all exposed electrical connections and terminal ends with a marine-grade anti-corrosion spray or dielectric grease.
- Disconnect battery cables (negative cable first) if the vessel will not be used for more than 90 days.
- Clean battery terminal ends with a solution of baking soda and water. Rinse thoroughly with clean water, dry completely, and apply a coat of dielectric grease before reconnecting or storing.

Fuel System Winterization

For the Mercury® outboard fuel system during seasonal storage:

- Fill the outboard fuel tank to 95% capacity to minimize condensation. Add fuel stabilizer and conditioner per Mercury recommendations.
- Run the engine long enough to circulate stabilized fuel through the entire system including the carburetor or fuel injection components.
- For storage longer than two months, consider draining the fuel system entirely. Consult the Mercury owner's manual for complete fuel system winterization procedures.
- Ethanol-blended fuels (E10) are particularly susceptible to phase separation during storage. Keep the tank full and treated to minimize water accumulation.

7.5 Recommissioning After Storage

144. Charge both batteries fully before any operation.
145. Inspect all systems visually — look for corrosion, pest damage, or deterioration.
146. Replace any expired safety equipment (VDS, fire extinguisher, PFDs).
147. Verify Mercury annual outboard service is current.
148. Test all lights — headlights, brake lights, turn signals, navigation lights.
149. Test bilge pump — manual and automatic.
150. Inspect all zerk fittings and grease before first use.
151. Complete the Pre-Ride Inspection (Section 4.6) before any road operation.
152. Complete the Pre-Launch Checklist (Section 5.14) before any water operation.

7.6 Cleaning & Care

Windshield, Windows & Acrylic Surfaces

Use a liquid household glass cleaner to remove normal dust and dirt. To remove oil, grease, or road tar, use isopropyl alcohol, then wash the surface with water. Dry gently with a soft cloth or chamois.

⚠ NOTICE

Do not use abrasive cleaners, combination cleaner-and-wax products, or solvents containing ethyl or methyl alcohol on acrylic surfaces. Do not use products containing ammonia, harsh soaps, or abrasives. Never use gasoline or cleaning solvent — these products will scratch or destroy acrylic surfaces.

Seats & Upholstery

Using a circular motion, remove excess dirt from seats with a clean, damp cloth and warm water. Substances such as tar, asphalt, and other soils will stain if not removed quickly. For stains, use a clean cloth and solvent-type vinyl cleaner, then wash the area with a damp cloth and mild liquid detergent. Rinse with cool water. Towel dry any remaining water. Do not allow water to pool in the seams. Do not use harsh chemicals or abrasives.

Interior

Use mild liquid detergent and warm water to clean interior surfaces. Remove detergent residue with a clean, damp cloth.

⚠ NOTICE

Do not spray liquids directly into the interior of the vehicle — liquids can damage electrical components. Handle liquids with care. Do not spray water directly into the upper or lower console, dash panel, or switch panel. Do not use high-pressure water on seats or any interior components.

Exterior Hull & Paint

After each water use — particularly after saltwater or brackish water operation — rinse the exterior with fresh water. Focus on the hull, underside, wheel wells, and all metal fittings. Follow with a thorough WD-40 application to all exposed metal components, fasteners, and hardware. WaterCar includes several cans of WD-40 with every vehicle shipment — use them generously and often per the Corrosion Prevention Program (Section 7.2 and 7.3). For general washing, use mild automotive detergent and a soft sponge or cloth. Avoid high-pressure washing of seals, door edges, electrical connectors, and the Mercury® outboard.

APPENDIX A

Delivery & New Owner Reference

Stainless Steel Care

The WaterCar EV uses 316 stainless steel for rails, fittings, fasteners, and hardware throughout the vessel. While stainless steel is corrosion-resistant, it still requires regular maintenance to prevent pitting and surface degradation, particularly in saltwater environments.

- After each use — especially in saltwater — wash all stainless steel surfaces with mild soap and cold or lukewarm water. Hosing alone will not dislodge embedded salt crystals.
- Dry all stainless steel surfaces thoroughly after washing.
- Apply a marine-grade stainless steel cleaning wax or polish with a soft, dry cloth. Allow to dry, then buff.
- Crevice corrosion (brownish discoloration where two stainless steel pieces meet) is caused by trapped moisture and impurities. Clean with a marine-grade metal polish using a sponge or small-bristled brush.
- Never use abrasive cleaners, steel wool, or chlorine-based detergents on stainless steel. On polished finishes, wipe in the direction of the polish lines — never across them.
- Never use silver cleaners on stainless steel.

Aluminum Hull, Paint & Non-Skid Surfaces

The WaterCar EV hull is constructed of an all-welded aluminum unibody using marine-grade 50-series and aircraft-quality 60-series aluminum alloys. The hull is epoxy-coated via a full 360° rotisserie process, with all internal structural cavities, stringers, and welded seams sealed against marine exposure. Despite this protection, aluminum requires specific maintenance practices that differ from fiberglass vessels. Salt particles and moisture are the primary causes of white spots, pitting, and corrosion on aluminum surfaces.

Aluminum Hull Washing

After every use — especially in saltwater — wash the entire hull with a soft cloth and mild marine detergent. Hosing alone will not dislodge all embedded salt crystals. Do not allow soap to dry on coated surfaces. Wash and dry the full circumference of all aluminum components. Apply an aluminum protectorant at least twice per year, or more frequently in saltwater environments. Neglect will cause pitting of the surface which cannot be reversed.

Painted Surfaces

Painted exterior surfaces should be waxed at least twice per year with a high-quality marine wax to protect against UV degradation, oxidation, and salt exposure. Do not wax over dirt — wash and rinse thoroughly before waxing. Never apply tape or adhesives directly to painted surfaces. Use care when covering painted surfaces — tarps can trap dirt and cause chafing. Use a frame to keep covers elevated and allow air circulation.

Non-Skid Deck Surfaces

Clean non-skid deck areas with a marine-safe deck cleaner and a stiff brush. Apply a non-skid deck protectant every two to three months to prevent dirt, soot, and biological matter from adhering. Use care when applying any protectant to ensure walkways are not made slippery.

General Cleaning Restrictions

- Never use abrasive cleaners, abrasive pads, acidic cleaners, or harsh chemicals on aluminum or painted surfaces. Even fine cleaning powders can scratch or burnish a mill-rolled aluminum surface.
- If pressure washing, use only the wide fan nozzle and keep the spray head in continuous motion. Never concentrate high-pressure water on a small area. Do not pressure wash the console, electrical connections, caulked seams, or the Mercury® outboard.
- Inspect and replace all damaged nylon bushings, washers, or other hardware designed to prevent contact between dissimilar metals. Galvanic corrosion between dissimilar metals is accelerated in saltwater environments.
- Whenever electrical or electronic changes are made to the vessel, have a qualified marine technician check aluminum components for stray currents. Ensure all electronic equipment is properly grounded with adequately sized wire.

Appendix A — Delivery & New Owner Reference

A.1 Care Package Contents

Every WaterCar EV is delivered with a care package. Inspect and confirm all items at delivery:

- Navigation light pole — check local laws for requirements before use
- Lug nut adapter and extra pack of lugs
- Blade fuses: 3x 5-amp, 3x 15-amp
- Spare 48V main fuse (400 amp)
- Spare 12V accessory fuse (300 amp)
- WD-40 — 8–10 cans. Spray all exposed metal components after every use, especially after water use.
- Red and Tacky Spray Grease — 1 can
- Allen wrench for canopy (if applicable)
- Front tow trailer hitch (if applicable)
- Tow bar hydraulic support angle irons — MUST be used while towing the WaterCar EV
- Eco Battery extension cord (green cord)
- Life jackets — 4 units
- Throw buoy
- Moving blanket
- Red bungee cords (2) — for front deflectors; wear items requiring periodic replacement
- Crescent wrench
- Screwdriver
- Grease gun for zerk fittings
- Scissor jack
- Jumper cables
- Extra Mercury lower unit fluid — 1 bottle
- Stereo plugs and wiring pigtails

A.2 First-Day Startup After Delivery

Batteries may arrive low or fully discharged due to transport. This is normal.

153. Connect the 48V battery charger (green Eco Battery extension cord) to shore power — charge until the LED shows solid green.
154. Connect the 12V battery to a standard lithium-compatible 12V charger if it reads below 12.4V.
155. Once both batteries are charged, follow the Power-On sequence in Section 4.7.
156. Contact us at WaterCar: (714) 253-7186 if you have any difficulty — call or text anytime.

A.3 Quick-Start — Land Operation

157. Press and hold 48V battery power button until green LED illuminates.
158. Press and hold 12V battery power button until LED blinks.
159. Turn BOTH red master switches (beside driver's seat) to ON.
160. Turn electric motor key switch to ON — listen for relay click.
161. FNR to NEUTRAL. Release park brake. Select FORWARD. Apply accelerator gradually.

A.4 Quick-Start — Water Entry

162. Complete Pre-Launch Checklist (Section 5.14).
163. Drive to water's edge. Electric drive key to OFF. FNR to NEUTRAL.
164. Attach kill lanyard to wrist.
165. Enter the water
166. Lower outboard. Set trim to approximately 45. Slowly enter water.
167. Once floating, start outboard. Confirm cooling tell-tale within 30 seconds.
168. Retract REAR wheels first (hold until pump tone), then FRONT wheels.

A.5 Quick-Start — Water Exit

169. Shut down outboard completely. Tilt outboard fully up.
170. Align with ramp. Hull contacts ramp.
171. Deploy FRONT wheels first (hold until pump tone), then REAR wheels.
172. Confirm all wheels fully deployed and locked.
173. Electric drive key ON. FNR to FORWARD. Drive out slowly.
174. Pull clear of ramp. Set park brake. Complete post-water inspection (Section 6.4).

APPENDIX B

Schematics & Technical Reference

Appendix B — Schematics & Technical Reference

Wiring Diagrams

12VDC - Main Distribution

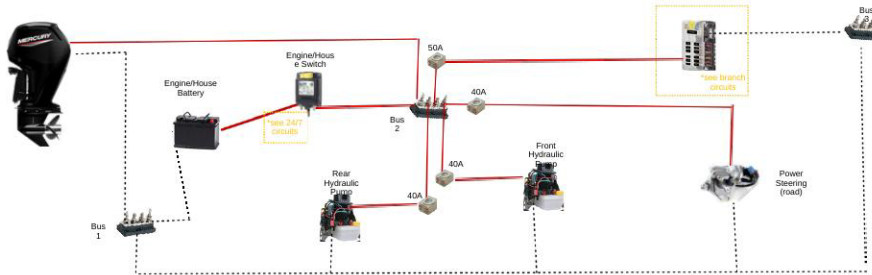

12VDC - 24/7 Circuits

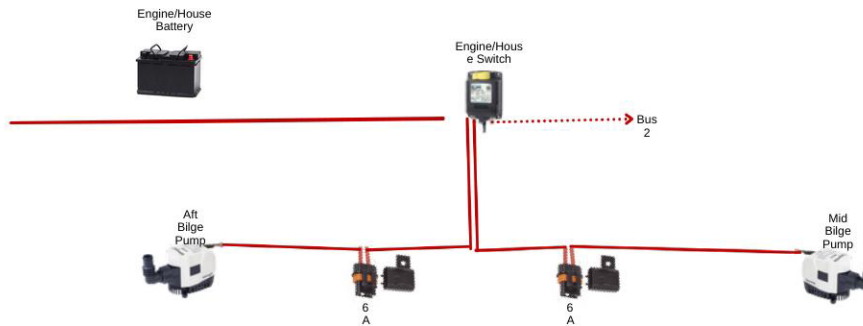

12V Branch Circuits - Bilge Pump Systems

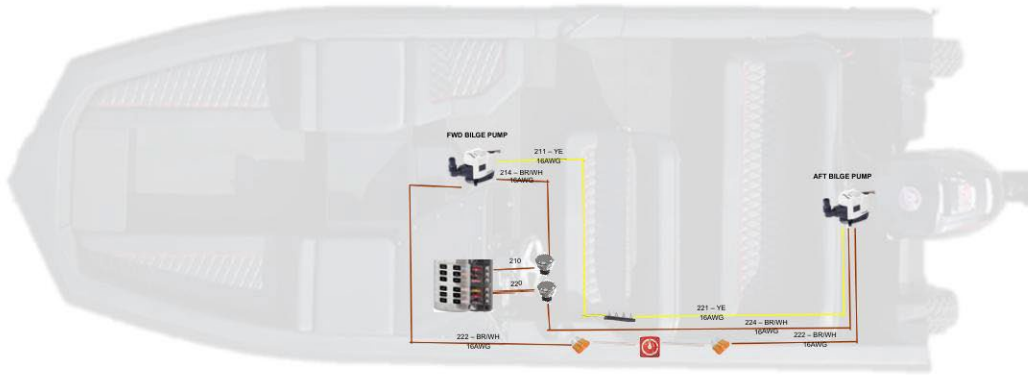

12V Branch Circuits - Navigation Systems

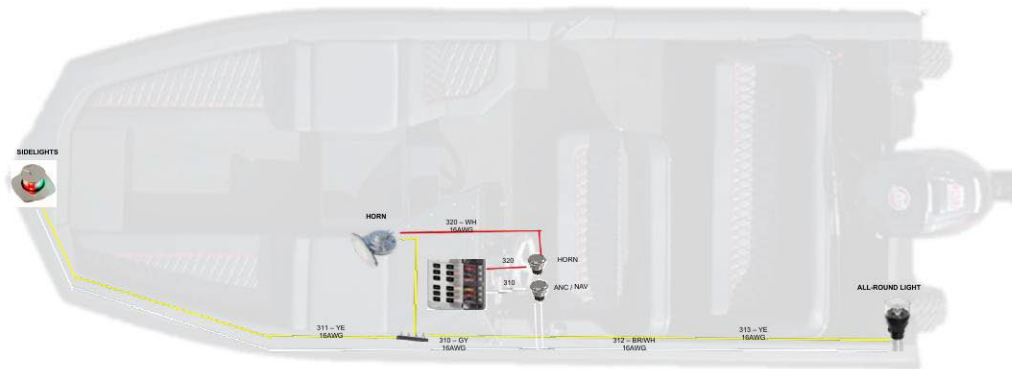

12V Branch Circuits - Hydraulic Systems

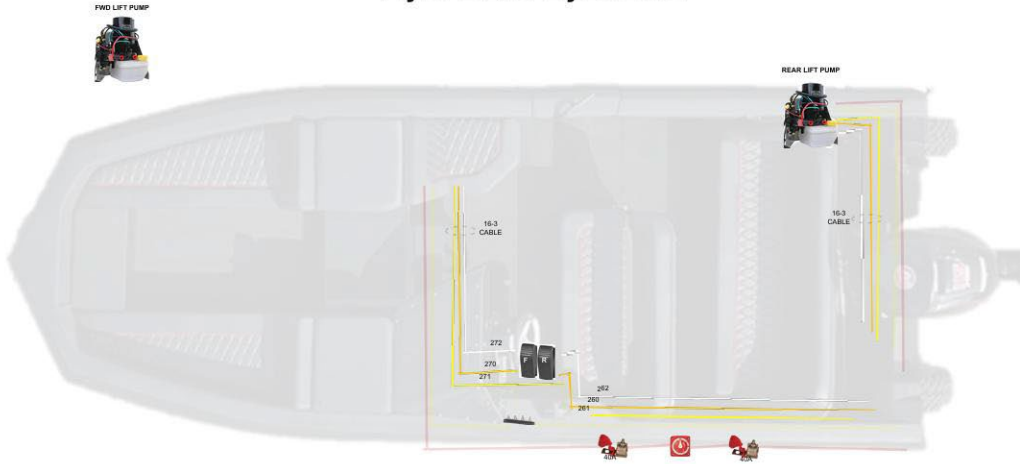

12V Branch Circuits - Turn Signals

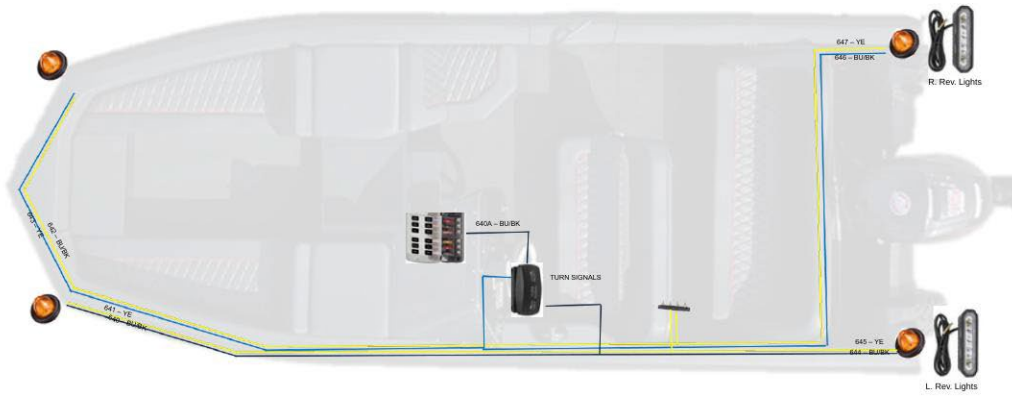

12V Branch Circuits - Helm Fuse Block

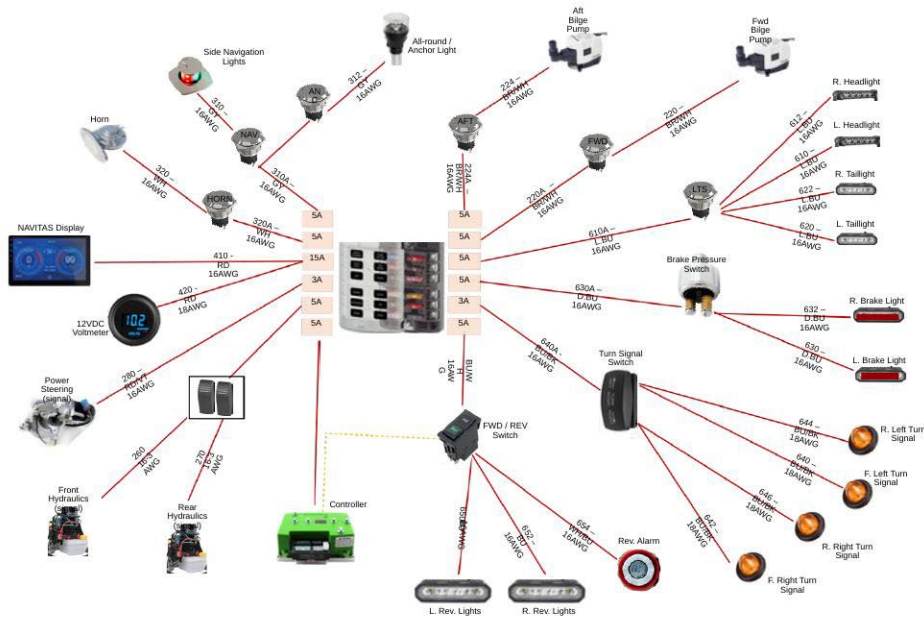

Hydraulic Schematics

FRONT HYDRAULIC SCHEMATIC

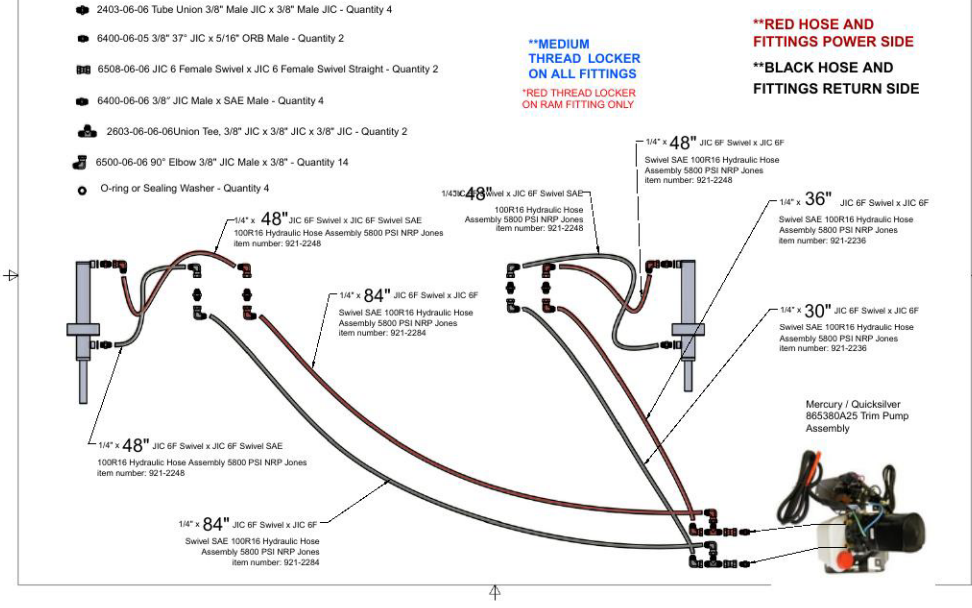

REAR HYDRAULIC SCHEMATIC

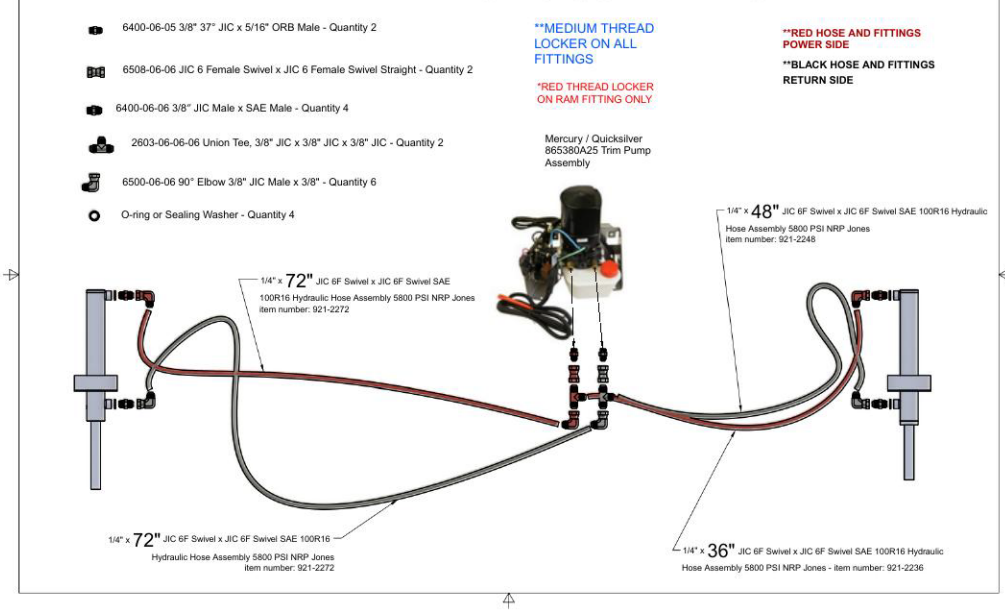

▲ NOTICE

Wiring schematics are provided as reference for qualified service technicians only. WaterCar Inc. reserves the right to change or update the electrical system on any unit at any time without prior notice. Contact WaterCar Corporate Headquarters for current electrical schematics applicable to your specific unit's serial number.

- 12VDC — Main Distribution & 24/7 Circuits
- 12V Branch Circuits — Bilge Pump & Auxiliary Systems
- 12V Branch Circuits — Hydraulic Systems & Turn Signals
- 12V Branch Circuits — Helm Fuse Block & Complete Schematic

Hydraulic Fitting Reference

Part No.	Description	Qty
2403-06-06	Tube Union 3/8" Male JIC x 3/8" Male JIC	4
6400-06-05	3/8" 37° JIC x 5/16" ORB Male — Power side	2
6508-06-06	JIC 6 Female Swivel x JIC 6 Female Swivel Straight	2
6400-06-06	3/8" JIC Male x SAE Male — Return side	4
2603-06-06-06	Union Tee, 3/8" JIC x 3/8" JIC x 3/8" JIC	2
6500-06-06 (front)	90° Elbow 3/8" JIC Male x 3/8" JIC	14
6500-06-06 (rear)	90° Elbow 3/8" JIC Male x 3/8" JIC	6

APPENDIX C Revision History

Appendix C — Revision History

Version	Date	Description
1.0	April 2025	Original publication.
2.0–7.0	Aug 2025	Iterative revisions: content restoration, images, console callouts, maintenance tables, warranty, appendices.
8.0	Jan 2026	Architectural rebuild: 18-section vehicle-first structure. Marine Package Divider added. Compliance language updated.
8.1 LSV	Feb 2026	LSV Edition: Pure LSV/road content only.
8.2 LSV	Apr 2026	Eco Battery full 17-code BMS table; IP67 statement; CAN resistor; Heated Battery. Epoch DP12120H full expansion.

8.3	Apr 2026	Six gap additions: maritime scope disclaimer; weather assessment; environmental discharge prohibition; schematics disclaimer; warranty performance exclusion; warranty severability.
9.0	Apr 2026	OEM rebuild from v8.3 PDF. All 18 sections complete. Hydraulic wheel system, delivery quick start, image placeholders, Club Car Onward and Eco Battery® Gen3 integrated.
10.0	Apr 2026	Safety sticker pages embedded (6 pages, 40 labels). Image sizing corrected. Footer page number corrected.
11.0	Apr 2026	Updated formatting
12.0	Apr 2026	Section 2.7 LSV sticker placement; spacer cleanup; document validation.
13–18	Apr 2026	Incremental refinements: marine sticker integration, occupant position diagrams, content continuity.
19.0	Apr 2026	Section 2.7 Safety Labels full rebuild in two-group CFO table format (Boat Safety Labels / Vehicle Safety Labels). 11 portrait sticker images rotated to landscape. All label-to-image mappings corrected. DPI-aware image sizing (150 DPI native). Phone number split: HQ (714) 253-7186 for company references, direct (714) 251-6687 reframed as Sales/Service Department. Cross-referenced CFO and Boston Whaler source documents to close content gaps: added Risk of Loss of Stability, Risk of Flooding (5 openings), expanded Launch Site Selection criteria (slipway, underwater hazards, undercuts, marshy ground, tidal range), added Door Latch / Hydraulic Fluid / Outboard Kill Switch rows to Pre-Ride Inspection.
21.0	Apr 2026	Cross-referenced Gibbs Humdinga and GEM 2024 LSV reference manuals to close remaining content gaps. Added Section 2.7 Hot Components & Exhibition Driving (motor/controller heat, combustibles clearance, stunt/wheelie/unauthorized-use prohibitions, after-accident inspection). Added Section 7.6 Cleaning & Care (windshield/acrylic surface care, seat and interior cleaning with electrical component protection notices, exterior hull rinse procedure). Existing Safety Labels section renumbered from 2.7 to 2.8; Label Location Summary renumbered from 2.8 to 2.9.
21.0	Apr 2026	Final BW 160 Super Sport cross-reference. Added: Swimming/Diving/Water Skiing safety (Section 5), Homeland Security restrictions, Static Electricity & Fueling, Certification Design Category (A/B/C/D), Out-of-Water Lifting/Sling procedures, VesselView 903 display (DualCommand™), Swim Ladder, Hinged Bow Cushions, Canopy Top, Bottom Painting & Antifouling, Stainless Steel Care, Aluminum Hull/Paint/Non-Skid Care, Battery & Electrical Winterization detail, Fuel System Winterization.
22.0	Apr 2026	All engineering placeholders resolved: GVWR updated to 2,995 lbs, GAWR front 1,438 / rear 1,557, DOT 4 brake fluid, Wilwood® brake pads (2mm min), wheel nut torque 85 ft-lbs, Mercury as specified on the capacity plate, Curtis 30-min timeout (2026+), AVAS under 20 mph fwd+rev, steering freeplay N/A. Cover subtitle updated to three-mode description. Marine-specific acknowledgment line added to Delivery Form. Zero PENDING items remaining. Aluminum hull care corrected (fiberglass content removed). Cover version 22.0.

APPENDIX D

Warranty & Legal

Appendix D — Warranty & Legal

D.1 WaterCar Inc. Limited Manufacturer's Warranty

⚠ NOTICE

This warranty supersedes all prior warranties, oral or written, express or implied. Read all terms carefully. For official documentation refer to WaterCar warranty paperwork provided at purchase.

B.1 Limited Warranty Coverage

WaterCar Inc. ("WaterCar") warrants to the original retail purchaser only that the WaterCar EV, when new and properly assembled, will be free from defects in materials and workmanship, subject to the exclusions and limitations set forth herein. This warranty is non-transferable and applies to the vessel/boat structure and WaterCar-manufactured components only. It does not extend to any third-party components.

B.2 Limited Warranty Periods

Component	Warranty Period
Structural Hull*	Five (5) years — repair only*
WaterCar- Manufactured Components*	One (1) year — parts and labor*
Upholstery, Canvas, Powder Coating*	One (1) year*

B.3 What Is Not Covered

- (a) Transportation costs;
- (b) Corrosion or saltwater damage;
- (c) Cosmetic damage;
- (d) Windshields;
- (e) Damage from abuse, misuse, or accident;
- (f) Modifications or non-approved parts;
- (g) Commercial use;
- (h) Acts of nature;
- (i) Unauthorized repairs;
- (j) Normal wear items including batteries, tires, brake pads, bearings, fuses;
- (k) Any representation or implication relating to speed, range, fuel consumption, or estimated performance characteristics.

B.4 No Implied Warranties

⚠ WARNING

TO THE EXTENT PERMITTED BY APPLICABLE LAW, WATERCAR EXPRESSLY DISCLAIMS ALL IMPLIED WARRANTIES, INCLUDING BUT NOT LIMITED TO IMPLIED WARRANTIES OF MERCHANTABILITY AND FITNESS FOR A PARTICULAR PURPOSE.

B.5 Limitation of Liability

⚠ WARNING

WATERCAR'S ENTIRE LIABILITY UNDER THIS WARRANTY IS LIMITED TO REPAIR OR REPLACEMENT OF DEFECTIVE PARTS. IN NO EVENT SHALL WATERCAR BE LIABLE FOR INCIDENTAL, CONSEQUENTIAL, SPECIAL, OR PUNITIVE DAMAGES OF ANY KIND.

B.6 Third-Party Component Warranties

The 48V Eco Battery is warranted separately by Eco Battery. Contact: 877-326-2288 | support@ecobattery.com

The 12V Epoch® Battery is warranted separately by Epoch Batteries. Contact: support@epochbatteries.com

The Mercury® outboard engine is warranted separately by Mercury Marine. Refer to Mercury warranty documentation supplied with your engine.

B.7 Warranty Service

Contact WaterCar Inc. to obtain a Return Authorization (RA) number before returning any component for warranty service.

info@watercar.com | www.watercar.com | (714) 253-7186

B.8 Modifications & Severability

⚠ NOTICE

The terms and conditions contained in this warranty may not be modified, altered, or waived by any action, inaction, or representation, whether oral or in writing, except upon the express written authority of a management-level employee of WaterCar Inc. The invalidity or unenforceability of any one or more provisions herein shall not affect the validity and enforceability of the other provisions.

B.9 Governing Law

This warranty is governed by the laws of the State of California. Any litigation shall be brought exclusively in the United States District Court for the Central District of California, or if that court lacks subject matter jurisdiction, in the appropriate state court of competent jurisdiction in Orange County, California.

WaterCar Inc.

17403 Newhope St., Fountain Valley, CA 92708
info@watercar.com | www.watercar.com | (714) 253-7186

© 2025–2026 WaterCar Inc. All Rights Reserved.
Reproduction or distribution of any part of this manual without written permission from WaterCar Inc. is prohibited.